

DELCO-REMY

SERVICE BULLETIN

BULLETIN 1R-118
Date 11-1-55
10 Pages Page 1
File Under:
R-RELAYS AND REGULATORS

D-R STANDARD THREE-UNIT WATERPROOF REGULATORS

(CIRCUIT "A"—MODEL 1119000 SERIES—MODEL 1118825 & 1118900 SERIES WITH LETTER "B" AFTER MODEL NUMBER.)

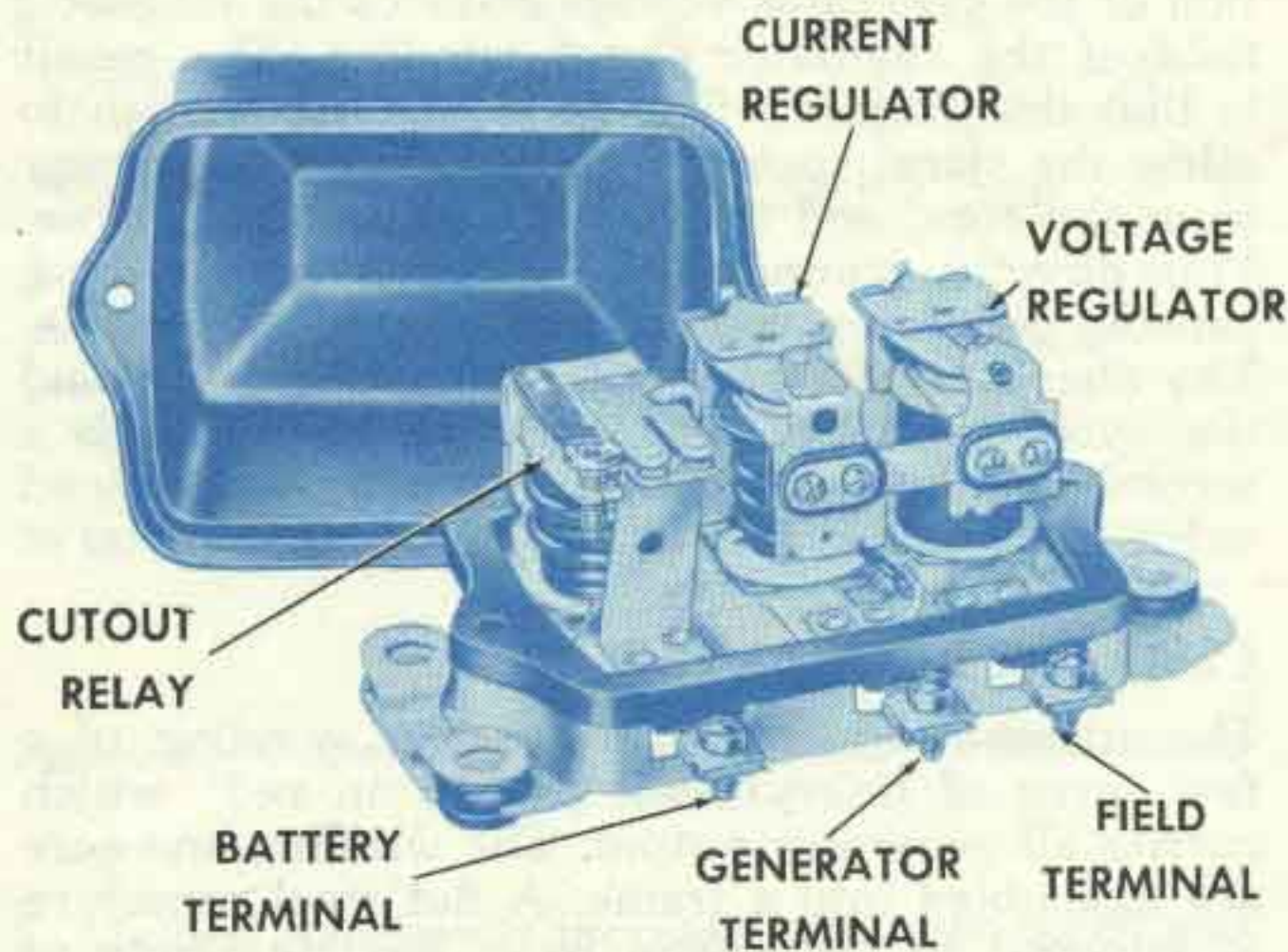

Figure 1—Delco-Remy standard three-unit waterproof regulator with cover removed.

This bulletin covers Delco-Remy standard three-unit waterproof generator regulators in the series beginning with Model 1119000, and also includes models in the 1118825 and 1118900 Series which have a suffix letter "B" following the model number. These regulators are designed for use with generators which have the field circuit insulated in the

generator but grounded in the regulator. A field connection of this type is designated as CIRCUIT "A."

Regulators covered in this bulletin except for aircraft and 24-volt units do not include an accelerator or series winding on the voltage regulator unit as do the regulators discussed in Bulletins 1R-115 and 1R-116. This difference makes necessary a different method of checking and adjusting the voltage setting. See "Voltage Setting" in section REGULATOR CHECKS AND ADJUSTMENTS.

Aircraft and 24-volt regulators of these series of models have an accelerator or series winding on the voltage regulator unit and the voltage setting should be adjusted in accordance with Bulletin 1R-116.

The regulator shown in Figure 1 consists of a cutout relay, a voltage regulator, and a current regulator unit. The cutout relay closes the generator-to-battery circuit when the generator voltage is sufficient to charge the battery, and it opens the circuit when the generator slows down or stops. The voltage regulator unit is a voltage-limiting device that prevents the system voltage from exceeding a specified maximum and thus protects the battery and other voltage-sensitive equipment. The current regulator unit is a current-limiting device

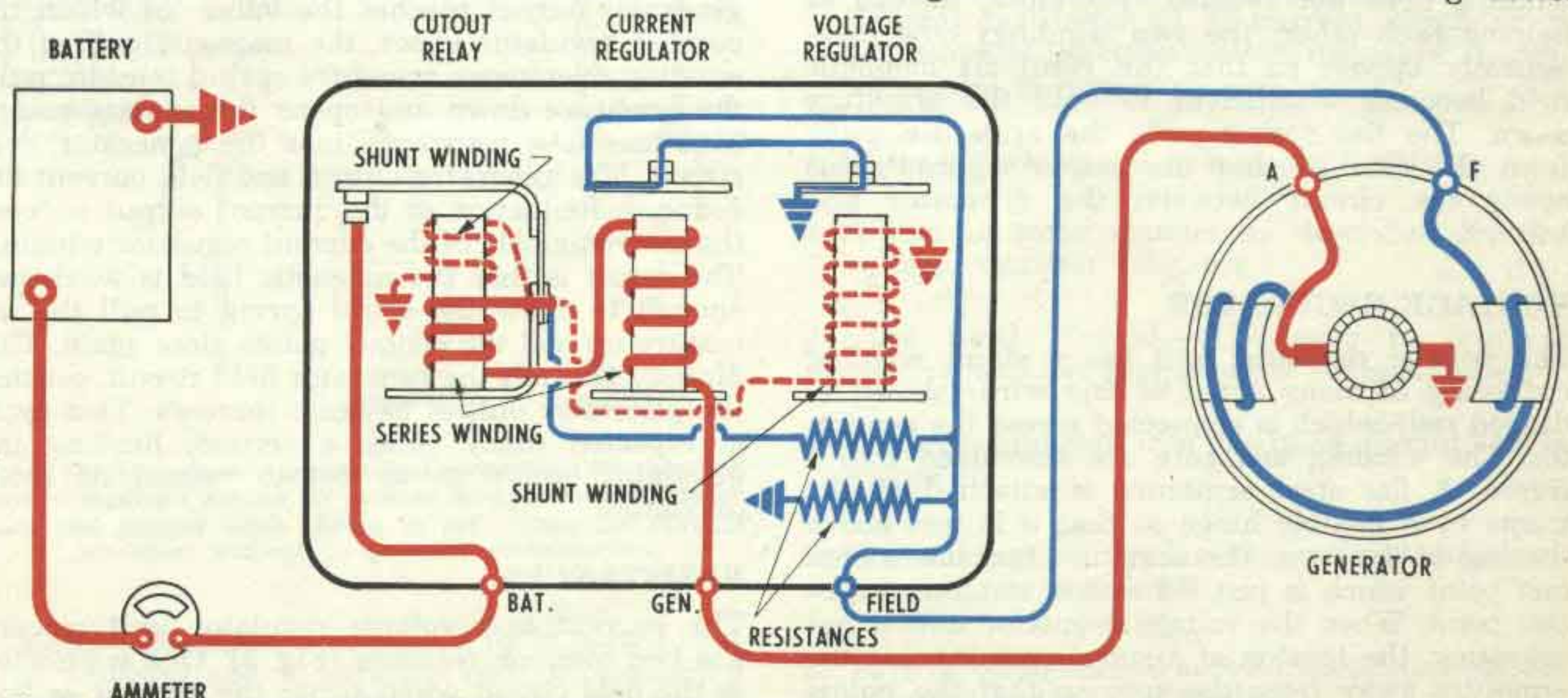

Figure 2—Wiring circuit of Delco-Remy standard three-unit waterproof regulator. The series windings in the cutout relay and current regulator are shown in solid red. The shunt windings in the cutout relay and voltage regulator are shown in dashed red. The field circuit and resistors are shown in blue.



that limits the generator output so as not to exceed its rated maximum. Figure 2 is a wiring diagram of this regulator.

CUTOUT RELAY

The cutout relay (Fig. 2) has two windings, a series winding of a few turns of heavy wire (shown in solid red) and a shunt winding of many turns of fine wire (shown in dashed red). The shunt winding is connected across the generator so that generator voltage is impressed upon it at all times. The series winding is connected in series with the charging circuit so that all generator output passes through it. The relay core and windings are assembled into a frame. A flat steel armature is attached to the frame by a flexible hinge so that it is centered just above the end of the core. The armature contact points are located just above the stationary contact points. When the generator is not operating, the armature contact points are held away from the stationary points by the tension of a flat spring riveted on the side of the armature.

CUTOUT RELAY ACTION—When the generator voltage builds up a value great enough to charge the battery, the magnetism induced by the relay windings is sufficient to pull the armature toward the core so that the contact points close. This completes the circuit between the generator and battery. The current which flows from the generator to the battery passes through the series winding in a direction to add to the magnetism holding the armature down and the contact points closed.

When the generator slows down or stops, current begins to flow from the battery to the generator. This reverse flow of current through the series winding causes a reversal of the series winding magnetic field. The magnetic field of the shunt winding does not reverse. Therefore, instead of helping each other, the two windings now magnetically oppose so that the resultant magnetic field becomes insufficient to hold the armature down. The flat spring pulls the armature away from the core so that the points separate; this opens the circuit between the generator and battery.

VOLTAGE REGULATOR

The voltage regulator unit has a shunt winding consisting of many turns of fine wire (shown in dashed red) which is connected across the generator. The winding and core are assembled into a frame. A flat steel armature is attached to the frame by a flexible hinge so that it is just above the end of the core. The armature contains a contact point which is just beneath a stationary contact point. When the voltage regulator unit is not operating, the tension of a spiral spring holds the armature away from the core so that the points

are in contact and the generator field circuit is completed to ground through them.

VOLTAGE REGULATOR ACTION—When the generator voltage reaches the value for which the voltage regulator unit is adjusted, the magnetic field produced by the winding overcomes the armature spring tension, pulls the armature down, and the contact points separate. This inserts resistance into the generator field circuit. The generator field current and voltage are reduced. Reduction of the generator voltage reduces the magnetic field of the regulator shunt winding. The result is that the magnetic field is weakened enough to allow the spiral spring to pull the armature away from the core, and the contact points again close. This directly grounds the generator field circuit, causing generator voltage and output to increase. The above cycle of action again takes place, and the cycle continues at a rate of many times a second, regulating the voltage to a predetermined value.

CURRENT REGULATOR

The current regulator has a series winding of a few turns of heavy wire (shown in red) which carries all generator output. The winding and core are assembled into a frame. A flat steel armature is attached to the frame by a flexible hinge so that it is just above the core. The armature has a contact point which is just below a stationary contact point. When the current regulator is not operating, the tension of a spiral spring holds the armature away from the core so that the points are in contact. In this position the generator field circuit is completed to ground through the current regulator contact points in series with the voltage regulator contact points.

CURRENT REGULATOR ACTION—When the generator output reaches the value for which the current regulator is set, the magnetic pull of the winding overcomes armature spring tension, pulls the armature down and opens the contact points. This inserts a resistance into the generator field circuit. The generator output and field current are reduced. Reduction of the current output reduces the magnetic field of the current regulator winding. The result is that the magnetic field is weakened enough to allow the spiral spring to pull the armature up and the contact points close again. This directly grounds the generator field circuit, causing the generator output to again increase. This cycle is repeated many times a second, limiting the generator output so as not to exceed its rated maximum.

RESISTANCES

The current and voltage regulator unit circuits use two common resistors (Fig. 2). One is inserted in the field circuit when either the current or vol-



tage regulator unit operates. The second resistor (Fig. 2) is connected between the regulator FIELD terminal and the cutout relay frame, which places it in parallel electrically with the generator field coils. The sudden reduction in field current occurring when either the current or voltage regulator contact points open, is accompanied by a surge of induced voltage in the field coils as the strength of the magnetic field changes. These surges are partially dissipated by the two resistors, thus preventing excessive arcing at the contact points.

TEMPERATURE COMPENSATION

Voltage regulators are compensated for temperature by means of a bimetal thermostatic hinge on the armature. This causes the regulator to regulate at a higher voltage when cold which partly

compensates for the fact that a higher voltage is required to charge a cold battery. Many current regulators also have a bimetal thermostatic hinge on the armature. This permits a somewhat higher generator output when the unit is cold, but causes the output to drop off as temperature increases.

REGULATOR POLARITY

Some regulators are designed for use with negative grounded systems, while other regulators are designed for use with positive grounded systems. Using the wrong polarity regulator on an installation will cause the regulator contact points to pit badly and give short life. As a safeguard against installation of the wrong polarity regulator, all regulators of this type have the model number and the polarity clearly stamped on the end of the regulator base.

REGULATOR MAINTENANCE

GENERAL INSTRUCTIONS

1. Mechanical checks and adjustments (air gaps, point opening) must be made with battery disconnected and regulator preferably off the vehicle.

CAUTION: The cutout relay contact points must never be closed by hand with the battery connected to the regulator. This would cause a high current to flow through the units which would seriously damage them.

2. Electrical checks and adjustments may be made either on or off the vehicle. The regulator must always be operated with the type generator for which it is designed.
3. The regulator must be mounted in the operating position when electrical settings are checked and adjusted and *it must be at operating temperature.**

**Operating temperature* for voltage regulator checking and adjusting is reached after 15 minutes of continuous operation of the voltage regulator unit, with $\frac{1}{4}$ ohm resistance in series with the battery, and with regulator cover in place. It is not necessary to measure the amount of current flowing during warm-up or testing of the voltage unit; however, it is important that no electrical load other than ignition be turned on during the test. (If a variable resistor is used in series with the battery, set to 1-10 amperes for warm-up period.) Operating temperature for temperature-compensated current regulators is reached after 15 minutes of operation with *current regulator operating* and cover in place. (Non-compensated current regulators

operate the same, hot or cold. Operating temperature, therefore, may be disregarded.)

4. Specified generator speeds for testing and adjusting.

a. Voltage Regulator

- (1) For passenger cars and trucks, 3,500 generator r.p.m.
- (2) Operating speed for constant speed engines (light aircraft engines included in this classification).
- (3) Governed speed for governed engines.

b. Current Regulator

- (1) All generators must be operated at a speed sufficient to produce current in excess of specified setting.
- (2) Voltage of the generator must be kept high enough to insure sufficient current output, but below the operating voltage of the voltage regulator unit.

5. After any tests or adjustments the generator on the vehicle must be polarized after leads are connected, *but before the engine is started*, as follows:

POLARIZING GENERATOR

After reconnecting leads, momentarily connect a jumper lead between the "GEN" and "BAT" terminals of the regulator. This allows a momentary surge of current to flow through the generator which correctly polarizes it. Failure to do this may result in severe damage to the equipment since reversed polarity causes vibration, arcing, and burning of the relay contact points.



QUICK CHECKS OF GENERATOR AND REGULATOR

In analyzing complaints of generator-regulator operation, any of several basic conditions may be found.



(1) Fully Charged Battery and Low Charging Rate—This indicates normal generator-regulator operation.

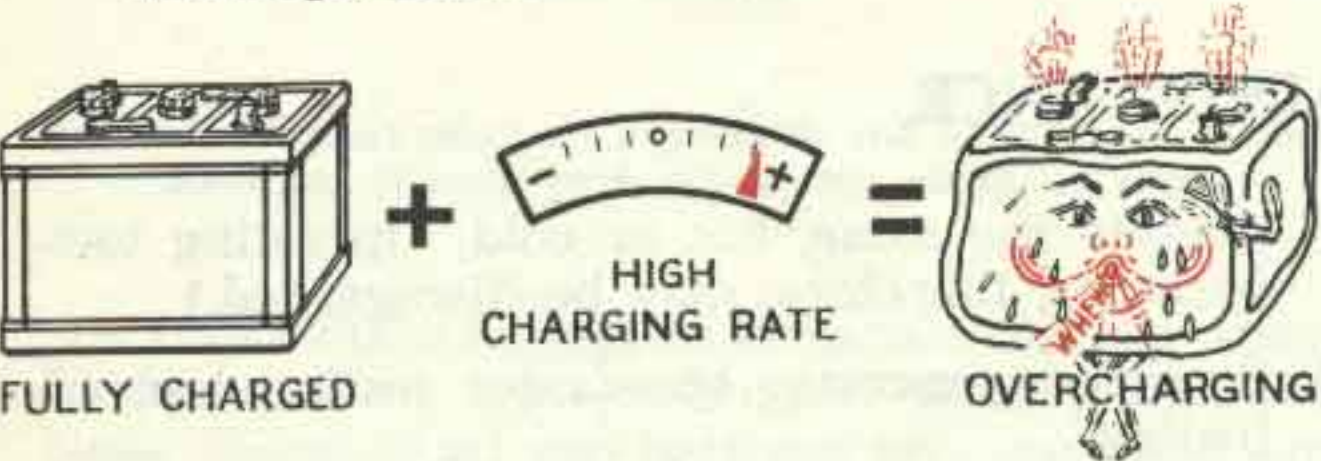

(2) Fully Charged Battery and a High Charging Rate—This usually indicates that the voltage regulator unit either is not limiting the generator voltage as it should or is set too high. A high charging rate to a fully charged battery will damage the battery and the accompanying high voltage is very injurious to all electrical units.

This operating condition may result from:

- (a) Improper voltage regulator setting.
- (b) Defective voltage regulator unit.
- (c) Grounded generator field circuit (in either generator, regulator, or wiring).
- (d) High temperature which reduces the resistance of the battery to charge so that it will accept a high charging rate even though the voltage regulator setting is normal.

If the trouble is not due to high temperature, determine the cause of trouble by disconnecting the lead from the regulator "F" terminal with the generator operating at medium speed.

If the output remains high, the generator field is grounded either in the generator (see Service Bulletin 1G-150) or in the wiring harness.

If the output drops off, the regulator is a fault, and it should be checked for a high voltage setting or grounds.

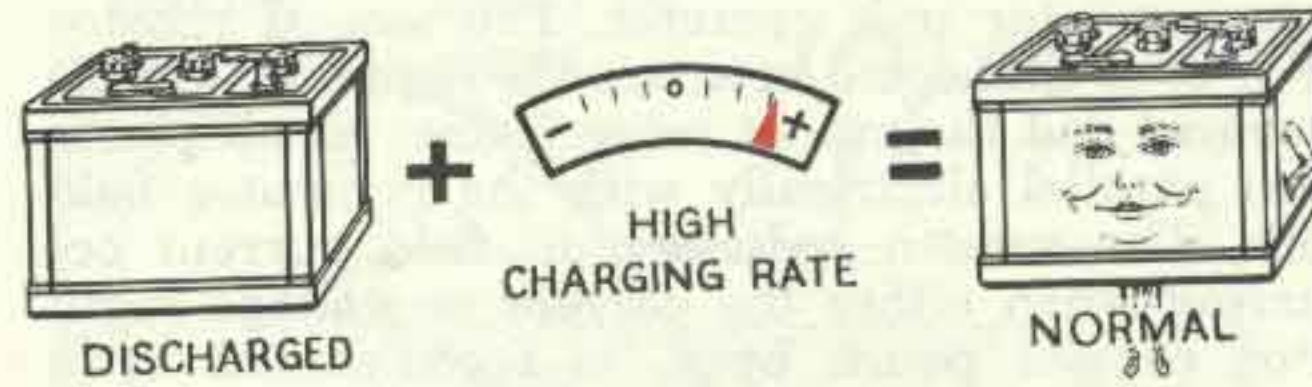

(3) Low Battery and High Charging Rate—This is normal generator-regulator action. Regulator setting may be checked as outlined in the following section.



(4) Low Battery and Low or No Charging Rate—

This condition could be due to:

- (a) Loose connections, frayed or damaged external wiring.
- (b) Defective battery.
- (c) High circuit resistance.
- (d) Low regulator setting.
- (e) Oxidized regulator contact points.
- (f) Defects within the generator.
- (g) Cutout relay not closing.
- (h) Open series circuit within regulator.
- (i) Generator not properly polarized.

If the condition is not caused by loose connections, frayed or damaged wires, proceed as follows to locate cause of trouble.

To determine whether the generator or regulator is at fault, momentarily ground the "F" terminal of the regulator and increase generator speed. If output does not increase, the generator is probably at fault and it should be checked as outlined in Bulletin 1G-150. Other causes for the output not increasing may be the relay not closing or an open series winding in the regulator. If the generator output increases, the trouble is due to:

- (a) A low voltage (or current) regulator setting.
- (b) Oxidized regulator contact points which insert excessive resistance into the generator field circuit so that output remains low.
- (c) Generator field circuit open within the regulator at the connections.

(5) Burned Resistances, Windings, or Contacts—These result from open circuit operation, open resistance units, or loose or intermittent connections in the charging circuit. Where burned



resistances, windings, or contacts are found, always check car wiring before installing a new regulator. Otherwise, the new regulator may also fail in the same way.

- (6) Burned Relay Contact Points—This may be due to reversed generator polarity. Generator polarity must be corrected after any checks of the regulator or generator, or after disconnecting and reconnecting leads.

CLEANING CONTACT POINTS

The contact points of a regulator will not operate indefinitely without some attention. It has been found that a great majority of all regulator trouble can be eliminated by a simple cleaning of the current and voltage regulator contact points, plus some possible readjustment.

The large flat point that should be cleaned with a spoon or riffler file is located on the armature of the voltage regulator, and is located on the upper contact support of the current regulator for negative

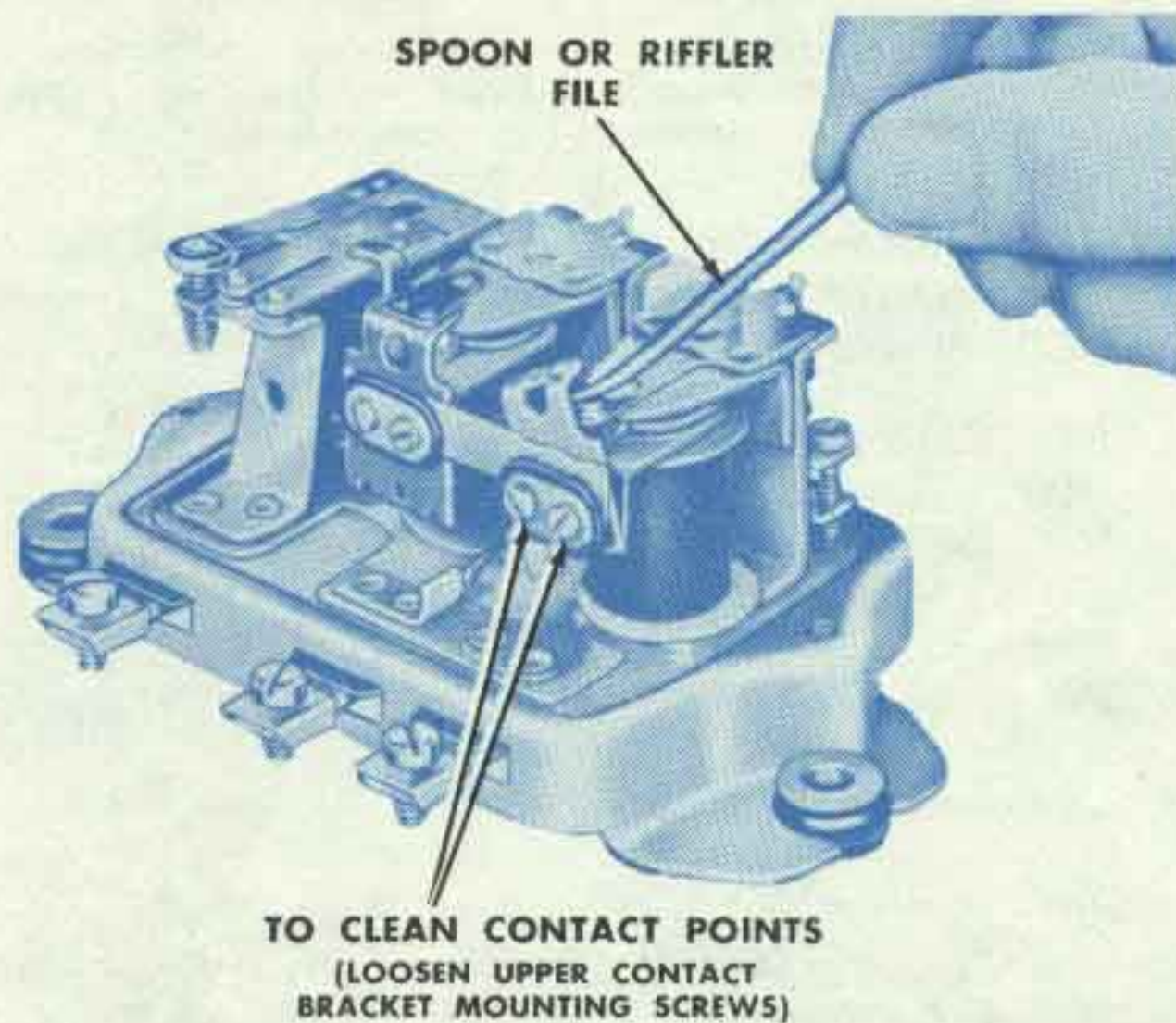

Figure 3—Illustrating use of spoon or riffler file to clean flat contact points in regulator.

grounded regulator units. This contact point will usually require the most attention. It is not necessary to have a flat surface on this contact point but all oxides should be removed with a riffler file so that pure metal is exposed and should be followed by a thorough wash with clear carbon tetrachloride. On regulators which have the flat contact point on the armature, loosen the upper contact bracket mounting screws so that the bracket can be tilted to one side (Fig. 3). On regulators which have the flat contact on the upper contact bracket, the bracket must be removed for cleaning the points.

The small soft-alloy contact point, located on the upper contact support bracket of the voltage regu-

lator and on the armature of the current regulator for negative grounded regulators, does not oxidize. This contact point may be cleaned with crocus cloth or other fine abrasive material followed by a thorough wash with clear carbon tetrachloride to remove any foreign material remaining on the contact surface.

Remove all oxides from the contact points but note that it is not necessary to remove any cavity that may have developed.

CAUTION—NEVER USE EMERY CLOTH OR SANDPAPER TO CLEAN THE CONTACT POINTS.

ADAPTING VOLTAGE REGULATOR SETTING FOR UNUSUAL CONDITIONS

The voltage regulator setting often must be "tailored" to adapt it to the battery and type of service. The ideal setting is that which will keep the battery at or near full charge with the minimum use of water. The "normal" setting (value shown in test specifications) usually will be satisfactory for average service. However, if service is above or below average, the setting must be tailored to fit the job. Either of two conditions which may exist will require tailoring: (1) battery is being overcharged (using too much water), (2) battery remains undercharged ($\frac{3}{4}$ charge or less). Corrections may be made as follows:

- (1) If battery uses too much water at normal setting, reduce voltage setting 0.1 or 0.2 of a volt and check for improved condition over a reasonable service period. Repeat until battery remains charged with a minimum use of water. It rarely will be necessary to go below 13.8 volts on a 12-volt system or 6.9 volts on a 6-volt system.

CAUTION: Whenever the voltage setting is reduced, the cutout relay must also be checked and reduced if necessary. It must be at least 0.5 of a volt less than voltage regulator setting.

- (2) If battery is consistently undercharged at normal setting, increase the voltage setting 0.1 of a volt and check for improved condition over a reasonable service period. Repeat until the battery remains charged with a minimum use of water. It rarely will be necessary to increase the voltage above 14.8 on a 12-volt system or 7.5 volts on a 6-volt system.

CAUTION: When increasing voltage avoid settings high enough to damage lights or other voltage-sensitive equipment during cold weather operation. Before tailoring the voltage setting for unusual conditions be sure the battery is normal—not sulfated, not permanently damaged due to having been overheated, not operating in too hot a location, and not poorly ventilated.



REGULATOR CHECKS AND ADJUSTMENTS

(See Delco-Remy Service Bulletins 1R-180 and 1R-185 for Specifications.)

Procedure: For best results the following steps should be taken in the sequence given.

(1) Bring voltage regulator to operating temperature, (2) Check voltage regulator, (3) Check cutout relay, (4) Bring current regulator to operating temperature, (5) Check current regulator.

VOLTAGE REGULATOR

Two checks and adjustments are required on the voltage regulator: air gap and voltage setting.

Air Gap—Push down on armature until contact points are just touching. Measure air gap between armature and winding core (Fig. 4). Adjust by loosening contact mounting screws and raising or lowering contact mounting bracket as required. Be sure the contact points are aligned and screws securely tightened after adjustment.

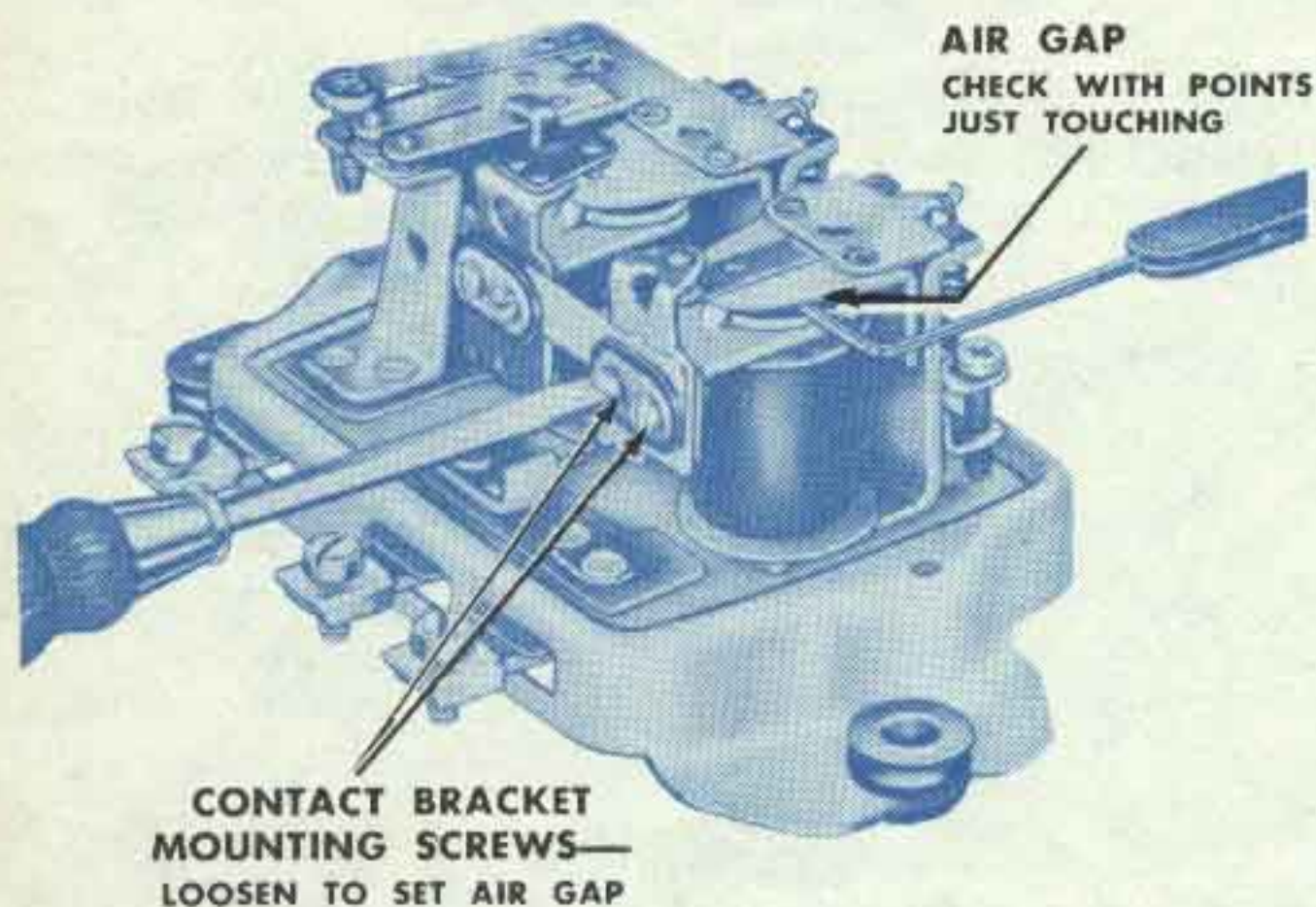

Figure 4—Voltage regulator air gap check and adjustment.

Voltage Setting (6- or 12-volt system)

Fixed 1/4 Ohm Resistance Method

1. Connect a 1/4 ohm fixed resistor (not less than 25 watts) into the charging circuit at "BAT" terminal of regulator (*in series with battery*) as in Figure 5.
2. Connect a voltmeter from regulator "BAT" terminal to ground (Fig. 5).
3. Operate generator at specified speed for 15 minutes. Regulator cover must be in place. (Regu-

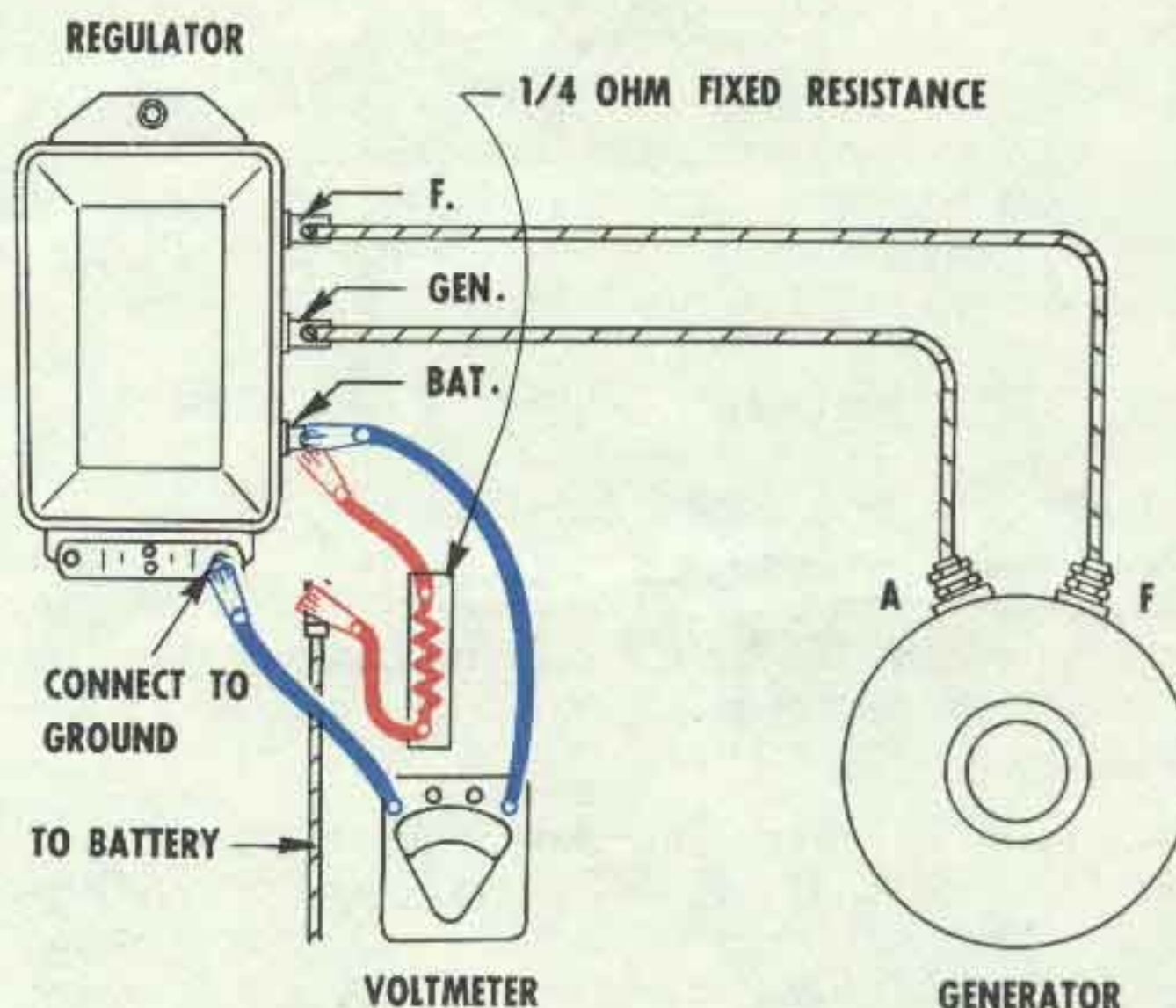

Figure 5—Fixed resistance and voltmeter connections to check voltage regulator settings. Fixed resistance leads shown in red and voltmeter leads shown in blue.

lator may now be considered to be at operating temperature, see paragraphs 3 and 4 in General Instructions.)

NOTE: IT IS NOT NECESSARY TO MEASURE THE AMOUNT OF CURRENT FLOWING DURING TESTING AND ADJUSTING. HOWEVER, IT IS IMPORTANT THAT NO ELECTRICAL LOAD OTHER THAN IGNITION BE TURNED ON DURING TEST.

4. Cycle the generator:

Method A—Move voltmeter lead from "BAT" to "GEN" terminal of regulator. Retard generator speed until generator voltage is reduced to 2 volts on a 6-volt system or 4 volts on a 12-volt system. Move voltmeter lead back to "BAT" terminal of regulator. Bring generator back to specified speed, and note voltage setting.

Method B—Connect a variable resistance into the field circuit, as in Figure 10. Turn out all resistance. Operate generator at specified speed. Slowly increase (turn in) resistance until generator voltage is reduced to 2 volts on a 6-volt system, or 4 volts on a 12-volt system. Turn out all resistance again, and note voltage setting (with voltmeter connected as in Figure 5). Regulator cover must be in place.

5. To adjust voltage setting turn adjusting screw (Fig. 6). Turn clockwise to increase setting and counterwise to decrease voltage setting.

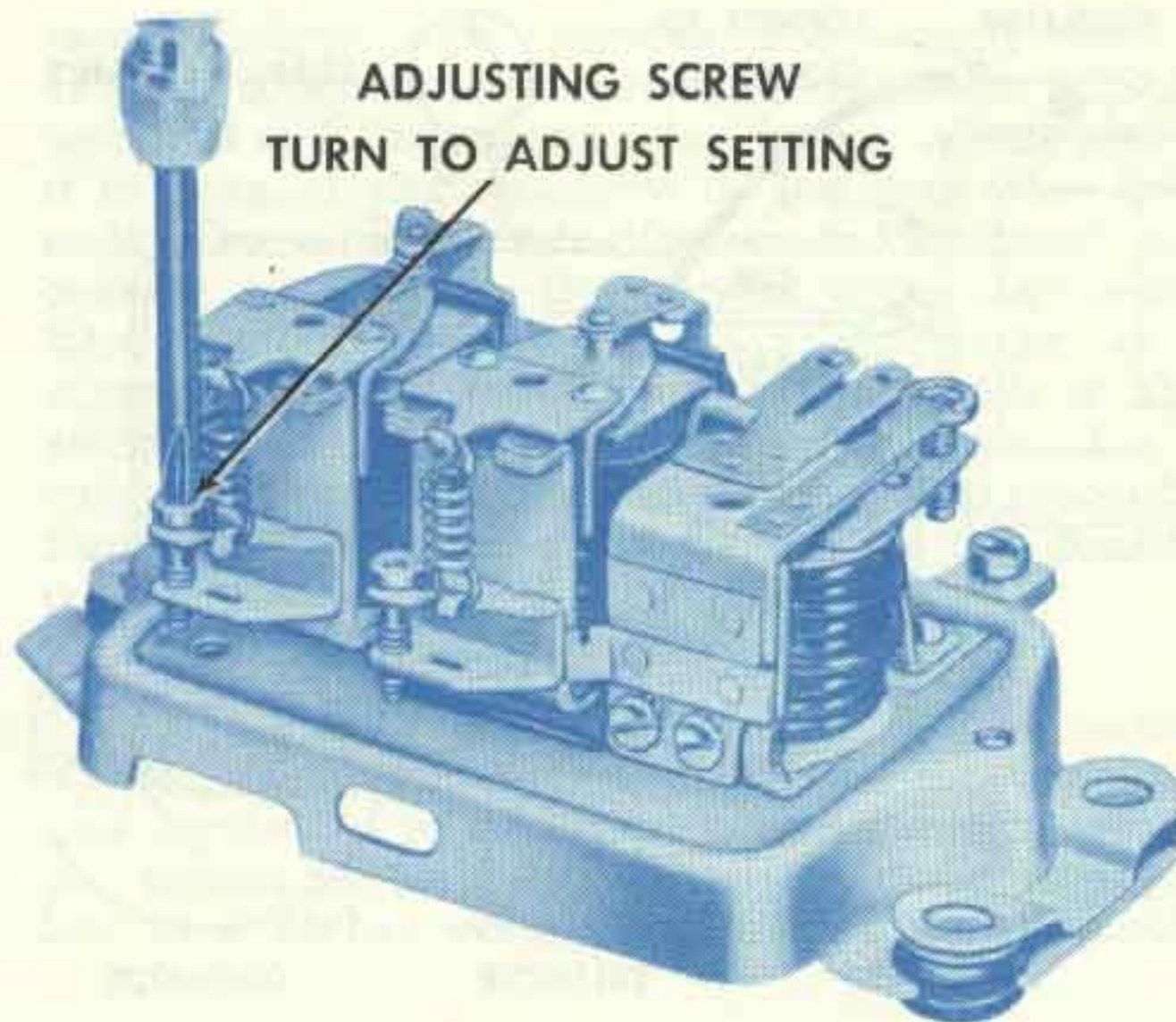

Figure 6—Adjusting voltage regulator setting.

CAUTION: If adjusting screw is turned down (clockwise) beyond range, spring support may not return when screw is backed off. In such case, turn screw counterclockwise until there is ample clearance between screw head and spring support. Then bend spring support up carefully until it touches the screw head. Final setting of the unit should always be made by increasing spring tension, never by reducing it. If setting is too high adjust unit below required value and then raise to exact setting by increasing spring tension. After each adjustment and before taking reading replace the regulator cover and cycle the generator.

Variable Resistance Method

1. Connect a variable resistance (not less than 25 watts) and an ammeter into the charging circuit (in series with battery) at "BAT" terminal of regulator as in Figure 7.
2. Connect a voltmeter from regulator "BAT" terminal to ground (Fig. 7).
3. Start generator and adjust variable resistance to obtain a current flow of not more than 10 amperes. Operate the generator at specified speed for 15 minutes. Regulator cover must be in place. (Regulator may now be considered to be at operating temperature; see paragraphs 3 and 4 in general instructions.)
4. Cycle the generator as explained in step 4 under "Fixed $\frac{1}{4}$ Ohm Resistance Method."
5. Adjust voltage setting as necessary, as explained in step 5 under "Fixed $\frac{1}{4}$ Ohm Resistance Method."

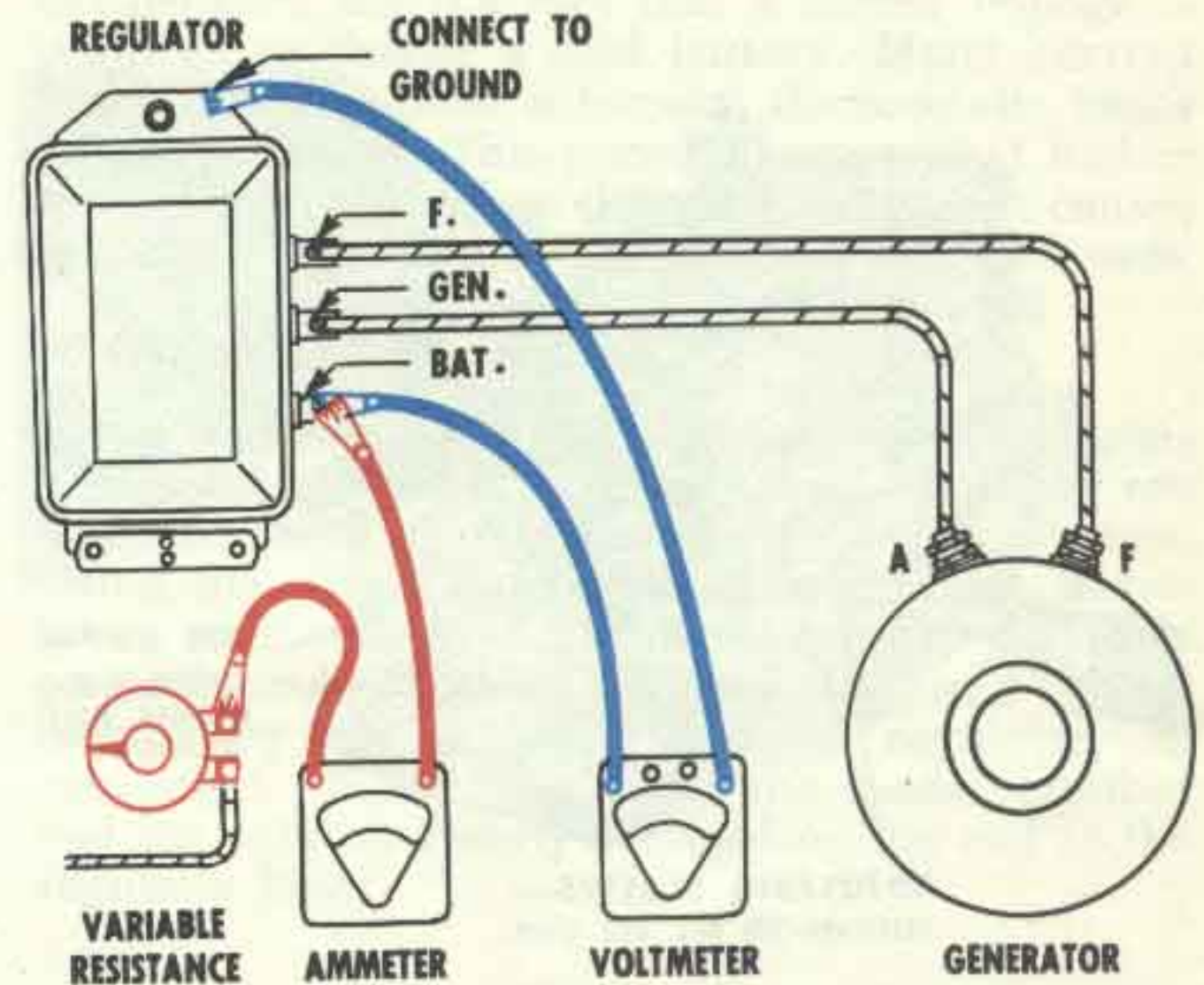

Figure 7—Variable resistance method meter connections for checking voltage regulator settings.

Correction for Ambient Temperature

Regulator specifications are given as a normal range in Test Specification Bulletin 1R-185 and are based on checks made at an ambient temperature of 125° F. Ambient temperature is the temperature of the air surrounding the regulator approximately $\frac{1}{4}$ of an inch from the regulator cover.

Voltage Correction Factor Rule—A correction of .15 volts for 12-volt regulators is made for every 10 degrees variation. If the ambient temperature is above 125° F, the correction is added to the voltmeter reading; if below 125° F, the correction is subtracted. Corrected readings should be checked against the normal range of settings. (Note: On 6-volt regulators a correction of .075 volts is made for every 10 degrees variation.)

For voltage regulator settings above or below normal, see section "Adapting Voltage Settings for Unusual Conditions." Extreme or abnormal operating conditions may require tailoring the voltage regulator setting.

CUTOUT RELAY CHECKS AND ADJUSTMENTS

The cutout relay requires three checks and adjustments: air gap, point opening and closing voltage. Air gap and point opening must be made with the battery lead disconnected from the regulator.

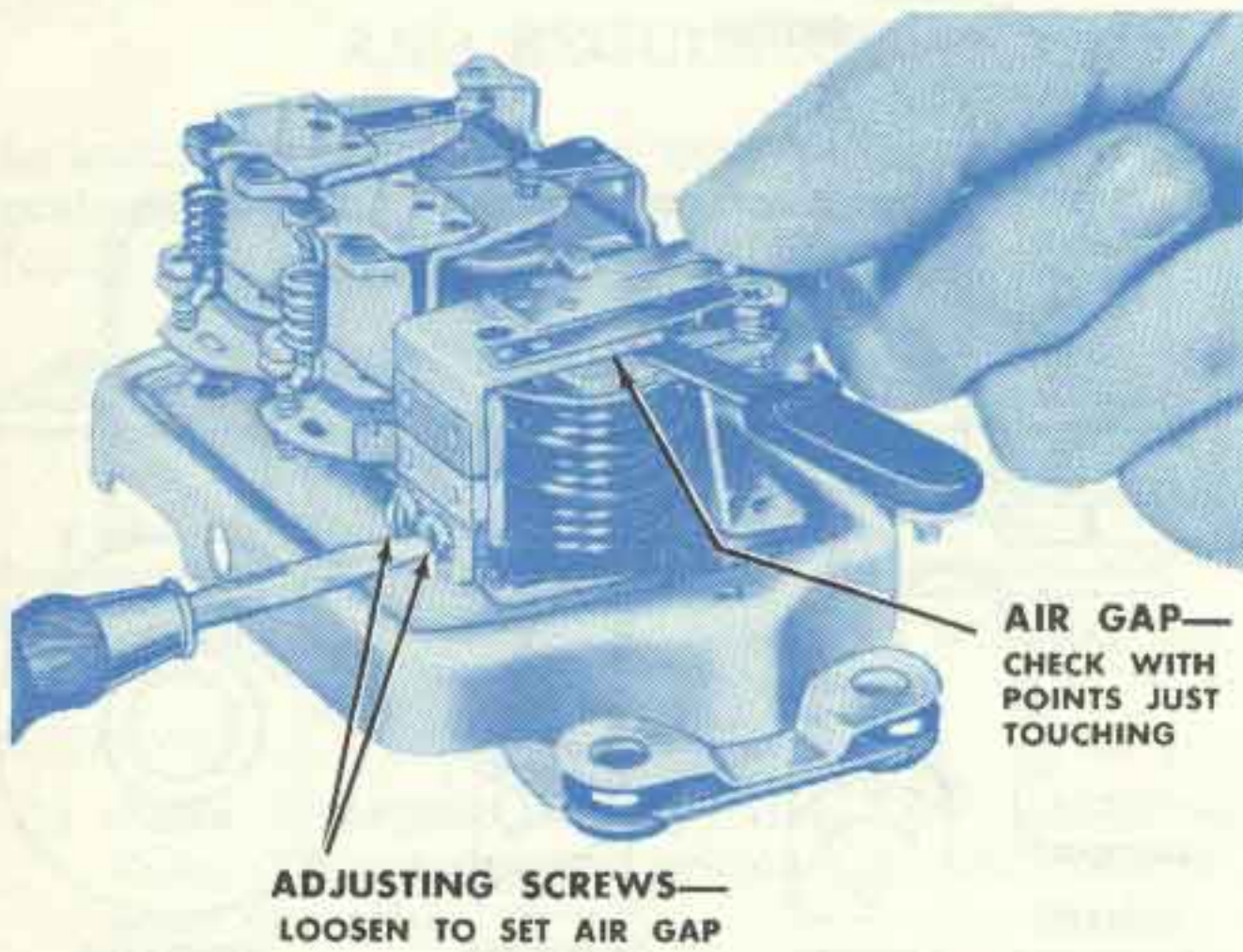

Figure 8—Cutout relay air gap check and adjustment. Battery must be disconnected when this check is made.

Air Gap—Place fingers on armature directly above contacts, move armature down until points just close. Measure air gap between armature and center of core (Fig. 8). On multiple contact point relays make sure that all points close simultaneously. Adjust air gap by adjusting two screws in back of relay and raise or lower armature as required. Tighten screws after adjustment.

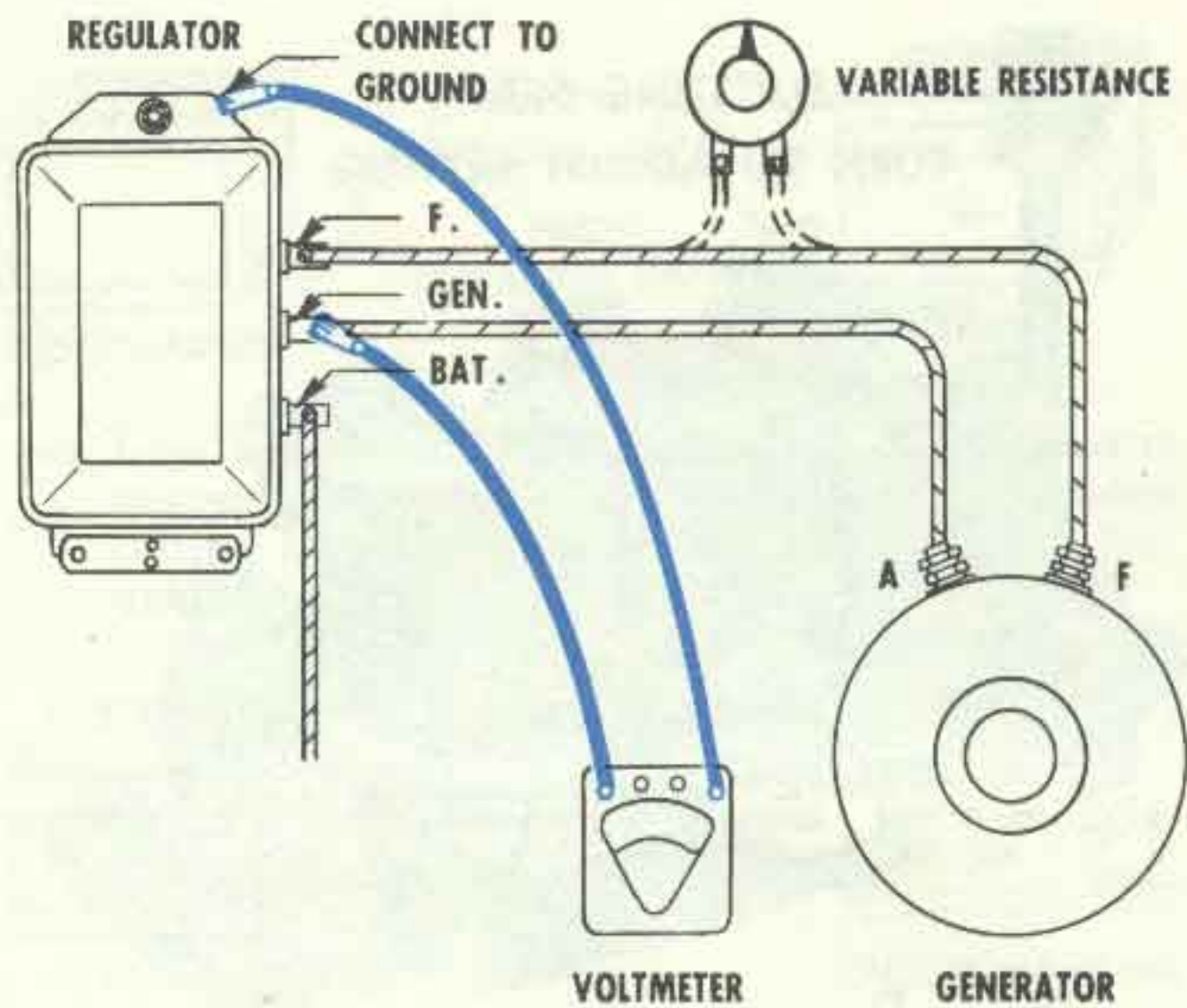

Figure 10—Voltmeter connections to check cutout relay closing voltage. Variable resistance may be connected as shown for cycling generator.

Point Opening—Check point opening and adjust by bending the upper armature stop (Fig. 9).

Closing Voltage—

1. Connect regulator to proper generator and battery. Connect voltmeter between the regulator "GEN" terminal and ground. (Fig. 10).

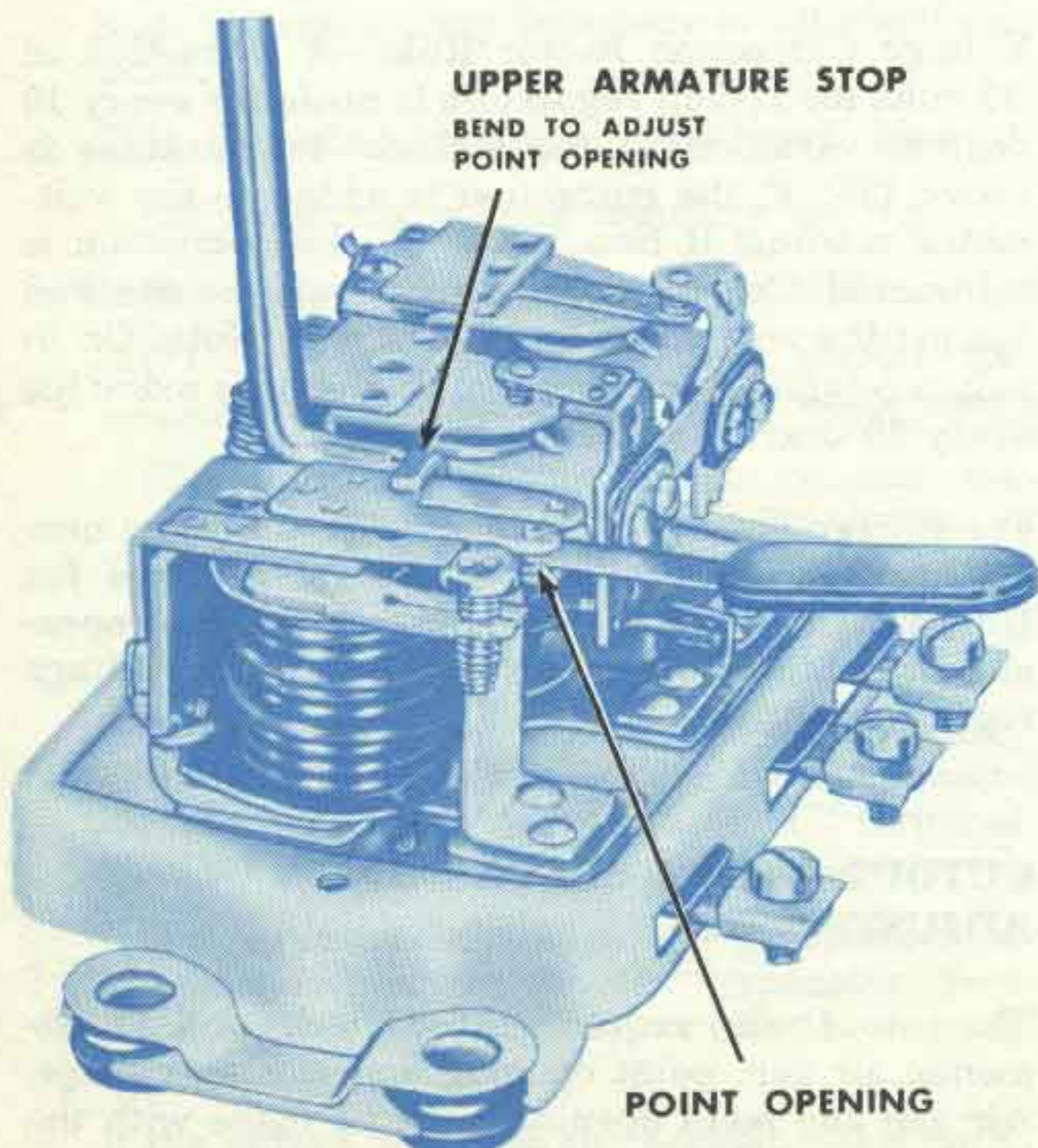

Figure 9—Cutout relay point opening check and adjustment. Battery must be disconnected when this check is made.

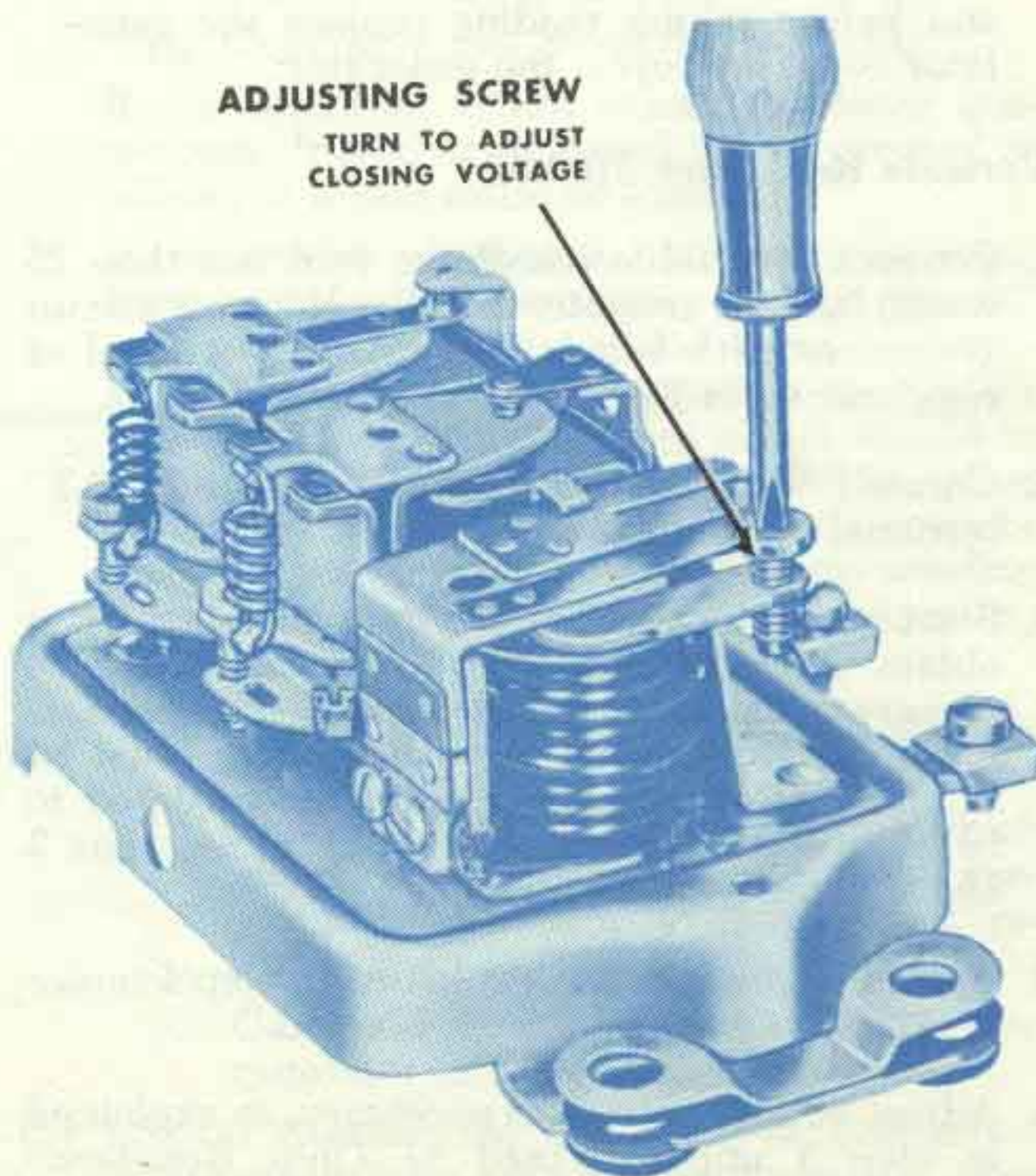

Figure 11—Adjustment of cutout relay closing voltage.

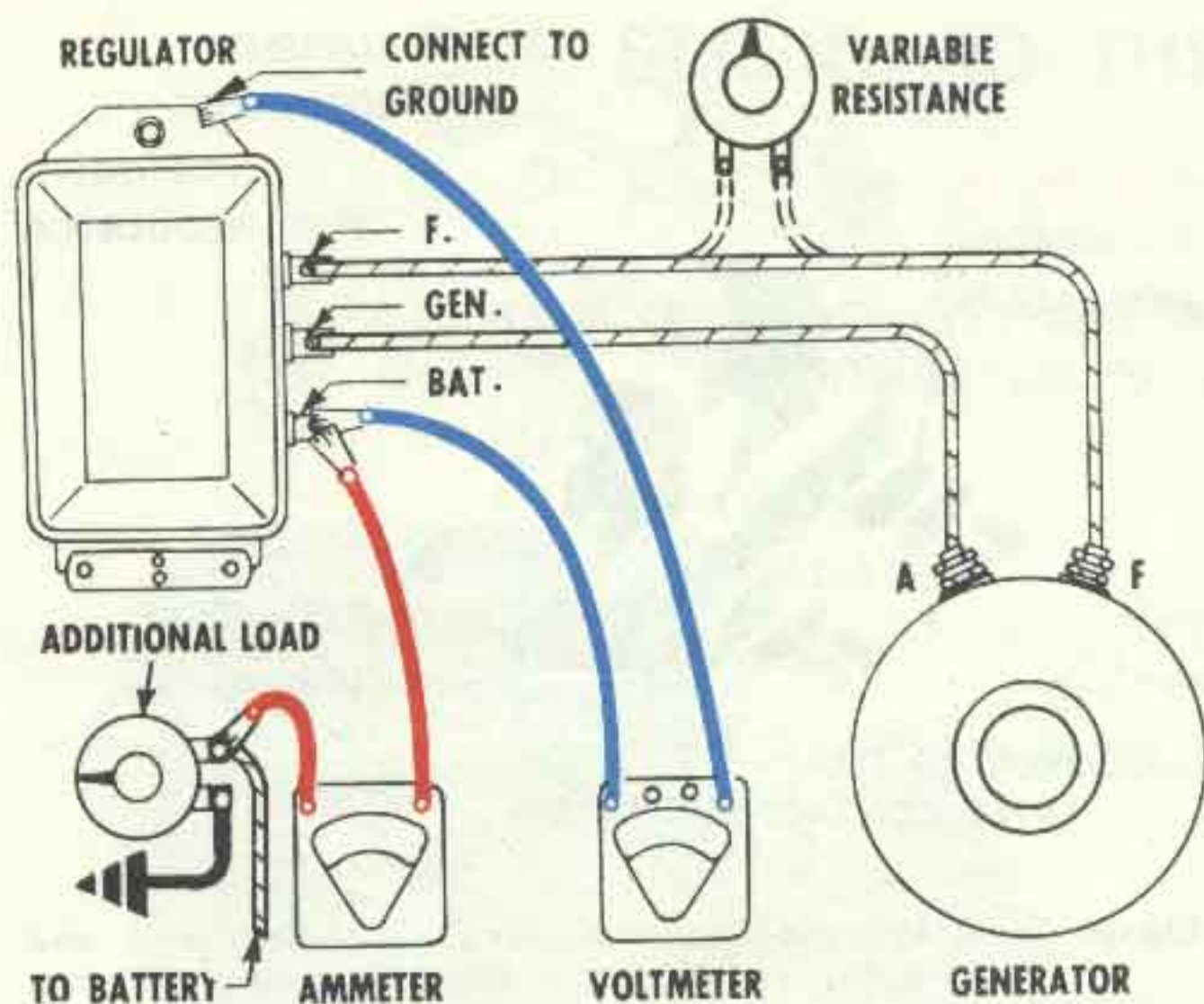

Figure 12—Connections for checking current regulator by load method.

2. Method A—Slowly increase generator speed and note relay closing voltage. Decrease generator speed and make sure the cutout relay points open.

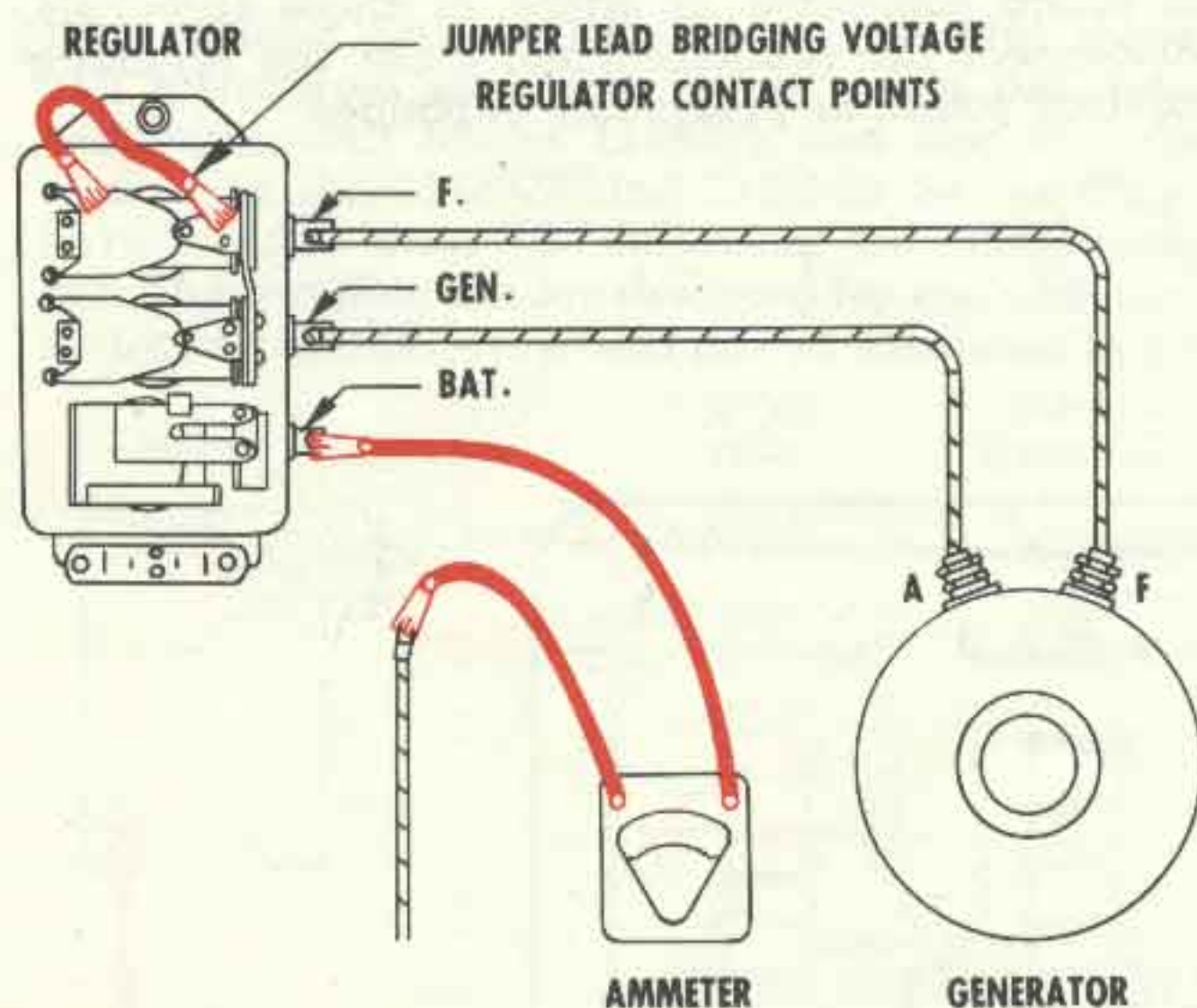

Figure 13—Ammeter and jumper lead connections for checking current regulator setting by jumper lead method. Ammeter leads and jumper leads shown in red. (Only for current regulators without temperature compensation.)

Method B—Make connections as in Step 1, but in addition add a variable resistor connected into the field circuit (Fig. 10). Use a 15 ohm-25

watt resistor for 6-volt systems, or 25 ohm-25 watt resistor for 12-volt systems. Operate generator at medium speed with variable resistance turned all in. Slowly decrease (turn out) the resistance until cutout relay points close. Note closing voltage. Slowly increase (turn in) resistance to make sure points open.

3. Adjust closing voltage (either method) by turning adjusting screw (Fig. 11). Turn screw clockwise to increase setting and counterclockwise to decrease setting.

CURRENT REGULATOR

Two checks and adjustments are required on the current regulator: air gap and current setting.

Air Gap—Check and adjust in exactly the same manner as for the voltage regulator.

Current Setting—Current regulator setting on current regulators having temperature compensation should be checked by the following method:

LOAD METHOD—

1. Connect ammeter into charging circuit, as in Figure 12.
2. Turn on all accessory load (lights, radio, etc.) and connect an additional load across the battery (such as a carbon pile or bank of lights) so as to drop the system voltage approximately one volt below the voltage regulator setting.
3. Operate generator at specified speed for 15 minutes *with cover in place*. (This establishes operating temperature; see paragraphs 3 and 4 in General Instructions.) If current regulator is *not* temperature-compensated, disregard 15-minute warm-up period.
4. Cycle generator and note current setting.
5. Adjust in same manner as described for the voltage regulator (Fig. 6).

Jumper Lead Method—(Use only for current regulators without temperature compensation.)

1. Connect ammeter into charging circuit, as in Figure 13.
2. Connect jumper lead across voltage regulator points, as in Figure 13.
3. Turn on all lights and accessories or load battery as in "2" under Load Method.



4. Operate generator at specified speed and note current setting.
5. Adjust in same manner as described for the voltage regulator (Fig. 6).

CAUTION—Do not use the *Quick Check Method* as previously outlined in Bulletin 1R-117 for checking current regulator on these *series* of regulators. Using the screw driver method will short both the voltage and current regulators which causes an uncontrolled output of the generator.

REPAIR SECTION

REGULATOR SPRING REPLACEMENT

If it becomes necessary to replace the spiral spring on either the current or voltage regulator unit, the new spring should first be hooked on the lower spring support and then stretched up until it can be hooked at the upper end. Stretch the spring only by means of a screwdriver blade inserted between the turns (or in a similar manner)—do not pry the spring into place, as this is likely to bend the spring supports. After installing a new spring, readjust the unit setting as already described.

REPLACING CONTACT SUPPORT BRACKETS

Voltage or current regulator unit contact support brackets can be replaced by following the relationship illustrated in Figure 14. Note particularly that the connector strap is insulated from both the vol-

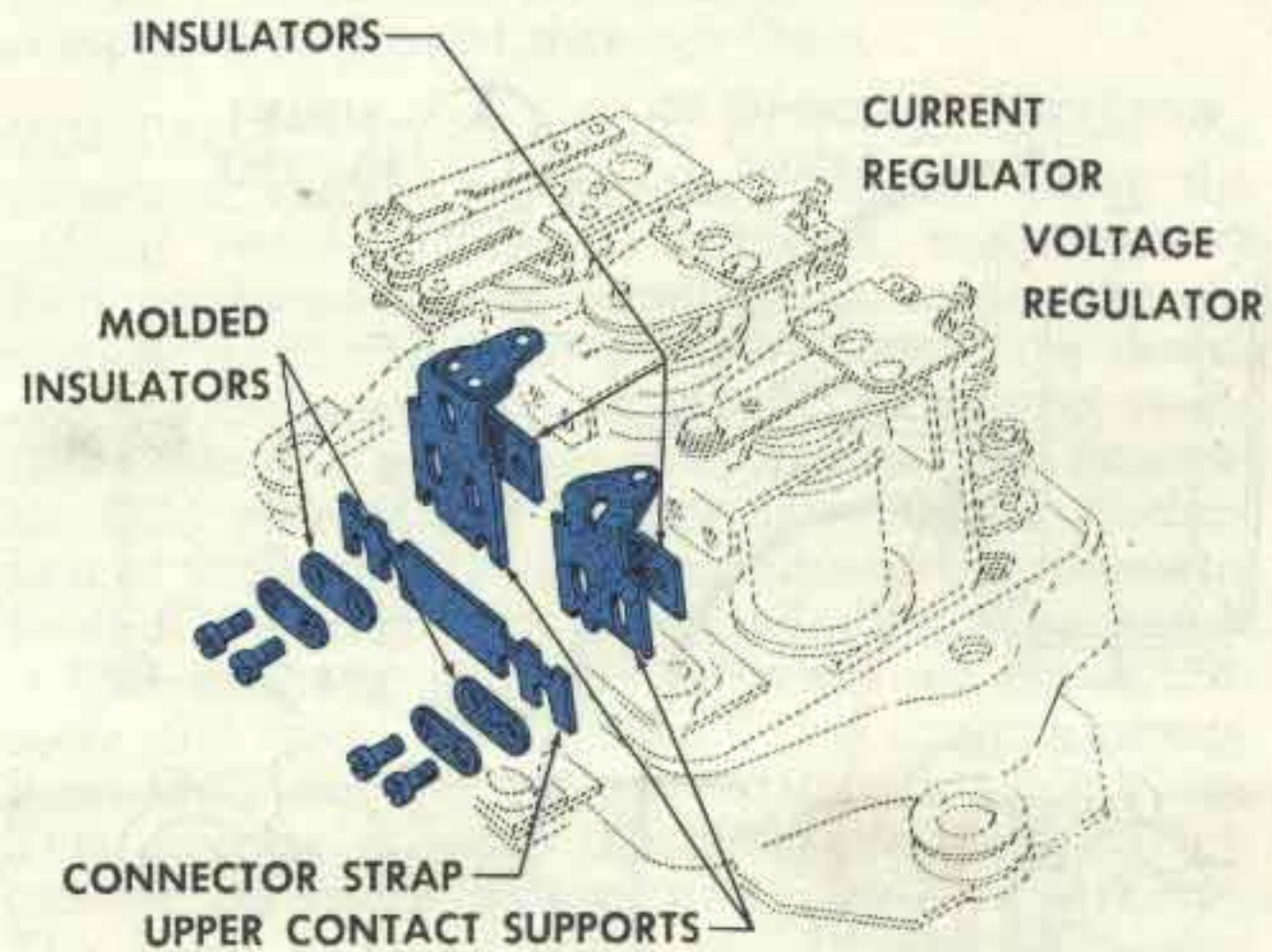

Figure 14—Relationship of insulators, connector strap and upper contact support brackets.

tage and current regulator unit contact mounting screws.

RADIO BY-PASS CONDENSERS

The installation of radio by-pass condensers on the field terminal of the regulator or generator will cause the regulator contact points to burn and oxidize so that generator output will be reduced and a rundown battery will result. If a condenser is found connected to either of these terminals, disconnect the condenser and clean the regulator contact points as previously explained.