

erg PSH-7BD Injection Carburetor

© 1956, 1958
 CORPORATION
 Indiana 46620

3-4. After the scoop assembly is installed, check the operation of the alternate air valves (ram air and hot air). Operation should be checked by operating the instrument panel control.

FUEL SYSTEMS AND CONNECTIONS

3-5. Before installing a PS carburetor on an engine, check the required fuel pressure chart shown here against the setting parts list of the carburetor to be certain the engine is equipped with the proper fuel pump for that carburetor. As can be seen from the chart there are three different required fuel pressures. It is important that inlet fuel pressure be held within plus or minus one pound of the specified pressure.

CARB. MODEL AND SETTING PARTS LIST			REQUIRED FUEL INLET PRESSURE
<u>PS-5C</u>	<u>PS-5CD</u>	<u>PSD-5C</u>	9.0 -14.0 lbs.
380179	391527	391435	
380208		391529	
380212		391572	
380223		391668	
380229			
380230			
391318			
391330			
391583			
391629			
<u>PS-7BD</u>	<u>PSH-7BD</u>	<u>PSD-7BD</u>	12.0 lbs. ± 1.0 lb.
391264	391624	391660	
391454	391640		
391635	391641		
	391677		
	391657		
<u>PS-5BD</u>	<u>PSH-5CD</u>		14.0 lbs. ± 1.0 lb.
391279	391603		
391486			
391561			
391569			
391621			

3-6. The fuel inlet connection is a 1/4 inch N.S.P.T. on all "PS" series carburetors. The fuel pressure and vapor vent openings are 1/8 inch N.S.P.T. Caution must be exercised in insuring that the threaded area of all connecting fittings to the carburetor are free from nicks, burrs or other thread damage which might cut or shave off aluminum cuttings from the regulator cover and force them into the unprotected cavity around the poppet valve.

CAUTION

Extreme care should also be exercised when applying Seal Lube or other thread compounds to the above connections. **USE SPARINGLY.** A large number of carburetor difficulties have been traced to the presence of thread compound and thread shavings in the metered fuel channels and poppet valve cavity of the carburetor causing erratic engine operation or complete engine stoppage.



3-7. If a check valve is installed in the vapor vent line be sure it is free and operating. The check valve should operate on 1.5 pounds **MAXIMUM** pressure.

THROTTLE AND MIXTURE CONTROL LEVERS

3-8. The control linkage from the cockpit control panel to the carburetor throttle and mixture controls must be supported in such a manner as to insulate the linkage from vibration as much as possible. The operation of the controls should be checked from the cockpit control panel. Enough slack should be available in the control linkage to prevent engine torque (on ground or in flight) from lifting the mixture control needle from its seat, causing unpredictable leaning.

a. The throttle lever on the carburetor is adjustable radially in 15 degree increments to conform to the control system of the aircraft. With the cockpit control in the **CLOSED** position, and the throttle lever on the carburetor in the **CLOSED** position, adjust the linkage as necessary.

b. The manual mixture and idle cut-off lever is not adjustable at the carburetor, all adjustments must be made on the cockpit control linkage. With the cockpit control in FULL RICH and the carburetor lever in FULL RICH, adjust the control linkage as necessary so ICO and FULL RICH can be obtained.

PREPARATION FOR USE

3-9. To eliminate corrosion and abnormal drying of the various diaphragms the carburetor is filled with a preservative oil before shipment. The carburetor must be drained, flushed and filled with fuel and allowed to soak in clean fuel to condition the fuel diaphragms.



a. Before installing the carburetor on an engine, remove the various shipping plugs, inlet screen, and the 1/8 inch pipe plug from the regulator cover, and allow the preservative oil to drain off. Wash the inlet screen in clean fuel and reinstall using a new 365533 strainer plug gasket.

b. After installing the carburetor on an engine, connect the fuel lines to the carburetor as soon as possible and use the following procedure to complete the flushing operation.

- (1) Open the fuel supply valve.
- (2) Place the mixture control in "RICH" and the throttle in the "WIDE OPEN" position.
- (3) Remove the 1/8 inch pipe plug from the bottom of the regulator cover.
- (4) Operate the boost pump until clean, oil-free fuel flows from the pipe plug opening.
- (5) Replace the 1/8 inch plug, and continue pumping fuel to the carburetor until oil-free fuel flows from the discharge nozzle.
- (6) Place the mixture control in "IDLE CUT-OFF" and shut off the fuel supply. Leave the carburetor soak for as long a period as practical before operating the engine.

NOTE

Because the carburetor is a closed fuel system it will remain full of fuel as long as the mixture control lever is in 'IDLE CUT-OFF'.

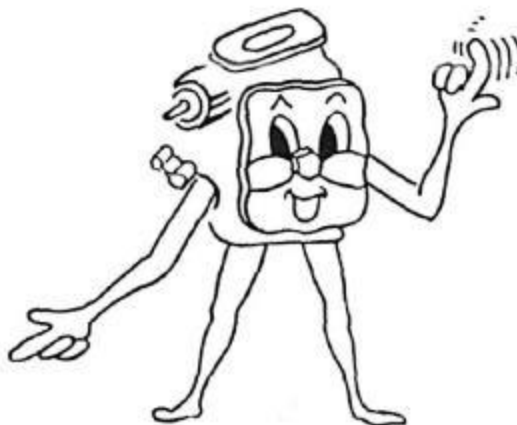

(7) An eight hour soak period is desired to condition the fuel diaphragms, that is, restore them to the pliable condition they were in when the carburetor was calibrated. This is particularly important in regard to making a final idle adjustment. If it is necessary to operate the aircraft without the full eight hour carburetor soak period the desired cruise metering may be erratic and the initial idle adjustment should be considered temporary and an idle readjustment will be necessary.

c. The soaking operation may be performed prior to installation on the engine if a portable pump and supply tank is available. Apply fuel to the carburetor inlet at 6.0 to 10.0 psi.

CAUTION

The above procedure is the only recommended method of soaking a new carburetor. The practice of soaking the carburetor by submersion in a pail of gasoline is definitely injurious to the air diaphragms as it allows fuel to come into direct contact with the air diaphragms, removing the vinyl coating from the diaphragms and causing them to become stiff after drying out, upsetting the metering qualities of the carburetor, and premature diaphragm service life.



SECTION IV

FIELD ADJUSTMENTS

4-1. IDLE SPEED AND MIXTURE ADJUSTMENT.

a. Start the engine and warm up in the usual manner until oil and cylinder head temperatures are normal.

b. Check magnetos in accordance with instructions furnished in the airplane operational handbook. If the "mag-drop" is normal, proceed with idle adjustment.

c. Close the throttle to idle (approximately 600 rpm). If the rpm increases appreciably after changing the idle mixture adjustment during the succeeding steps, readjust the idle speed to the desired rpm.

NOTE

If the airplane has variable pitch propeller, the idle mixture should be set with the propeller in full low fixed pitch. Also aircraft that employ fuel boost pump pressure for ground, take-off and landing operations, the idle mixture must be adjusted with the fuel boost pump "ON".

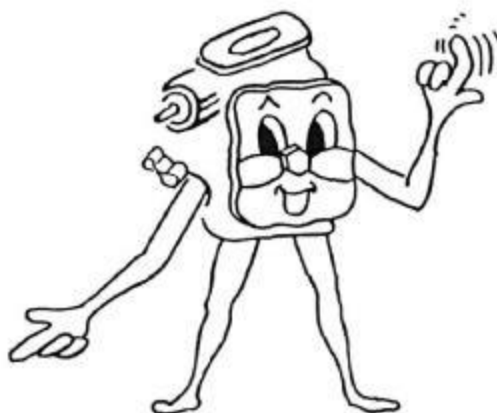

d. When the idling speed has been stabilized, move the cockpit mixture control lever with a smooth, steady pull, into the "IDLE CUT-OFF" position and observe the tachometer for any change during the "leaning" process. Caution must be exercised to return the mixture control to the "FULL-RICH" position before the rpm can drop to a point where the engine cuts out. An increase of more than 10 rpm while "leaning out" indicates a rich idle mixture. An immediate decrease in rpm (if not preceded by a momentary increase) indicates the idle mixture is too lean. The same indication of idle mixture is obtained by watching the manifold pressure gage. If the manifold pressure holds steady momentarily, then rises as engine

speed decreases, the idle mixture is correct. If the manifold pressure drops then rises as the manual mixture control is moved to idle cut-off, the mixture is too rich. If the manifold pressure increases immediately as the mixture control is moved toward idle cut-off, the mixture is too lean.

e. If steps (c) and (d) indicate that the idle adjustment is too rich or too lean, turn the idle mixture adjustment one or two notches in the direction required for correction, and check this new position by repeating steps (c) and (d). Make additional adjustments as necessary until a check with steps (c) and (d) results in a momentary pick-up of approximately five (never more than ten) rpm.

f. Each time an adjustment is changed, clear the engine by running it up to approximately 2000 rpm before making mixture check (steps c and d).

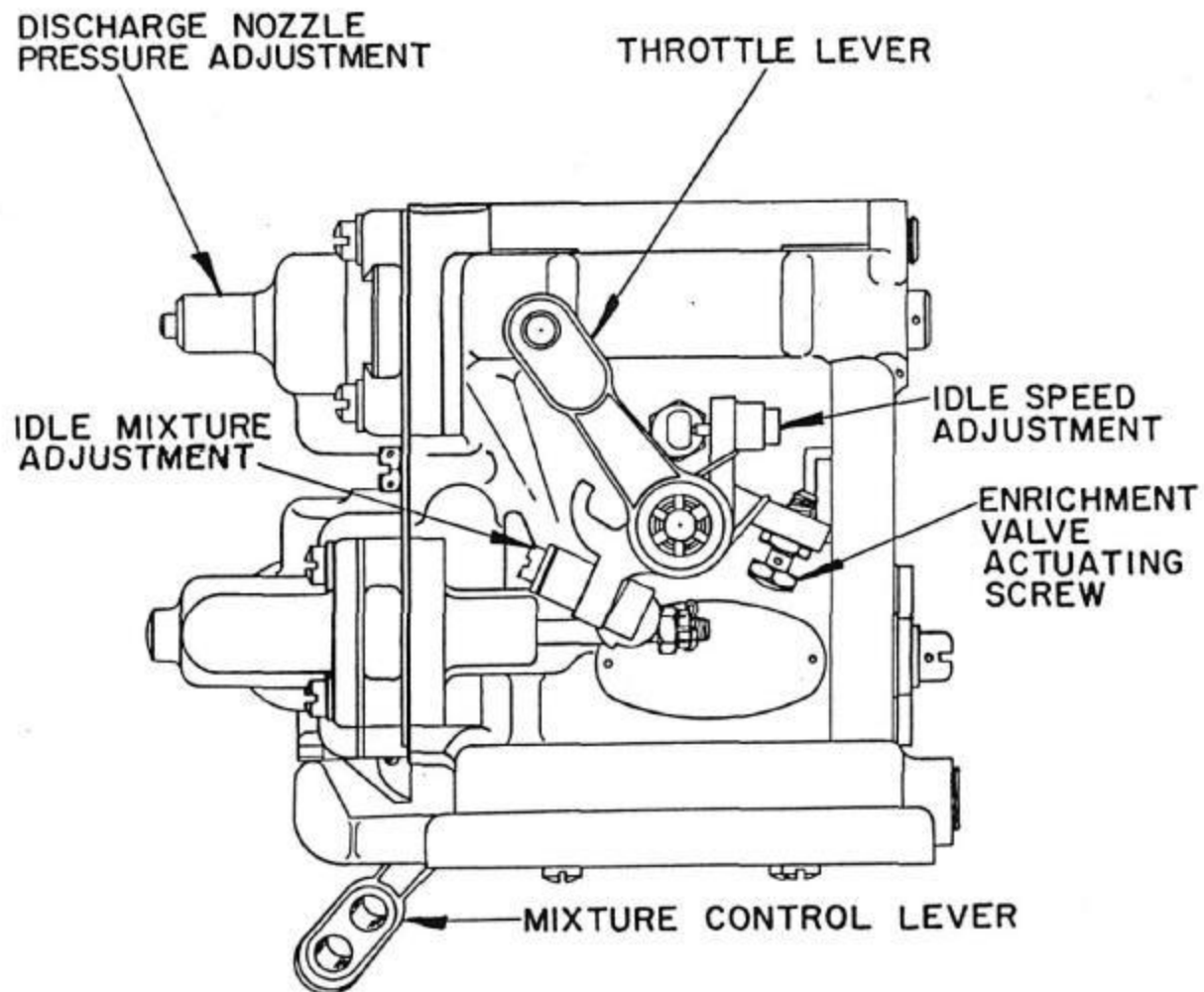

Figure 9. Idle Speed and Mixture Adjustments

g. Make the final adjustment of the idle speed adjustment to obtain the desired idling rpm with closed throttle.

h. This method of setting idle mixture strives to obtain the desired idle rpm with the lowest manifold pressure. In case the setting does not remain stable, check the idle linkage; any looseness in this linkage would cause erratic idling. In all cases, allowance should be made for the effect of weather conditions upon idling adjustment. The relation of the airplane to the direction of the prevailing wind will have an effect on the propeller load and thus on its rpm; hence it is advisable to make the idle setting with the airplane cross-wind.

4-2. Carburetor idle speed and mixture adjustments made according to the above method should require very little further attention except for extreme variations in temperature and altitude.

ENRICHMENT VALVE ADJUSTMENT

4-3. When the desired idle mixture and idle speed adjustments have been made, it is necessary to check and if necessary, readjust the mechanical enrichment valve opening point on the following model "PS" carburetors: PS-5C, PS-5CD, PSD-5C and PSH-5CD.

a. Refer to the chart (Figure 10) for the correct setting of the enrichment valve for the parts list of the carburetor effected. With the correct gage inserted square over the throttle stop (Figure 11), open the throttle valve until the lever contacts the angle on the gage. At this point, the enrichment valve actuating screw "A" must just contact the idle and enrichment valve control rod.

b. With the enrichment valve actuating screw set, tighten the locknut and safety wire.

4-4. It is important that on the above listed carburetors the enrichment valve setting be made AFTER the idle speed and mixture adjustment has been made as a change in idle adjustment can effect fuel flow in the cruise range. It can be seen by referring back to figure 2, that the idle needle on these carburetors not only controls idle flow, but also has a cruise step. The relation of the idle needle to the needle seat determines the point at which power enrichment fuel is available (when the cruise step moves out of the seat). The enrichment valve actuating screw on the throttle lever (a, Figure 11), allows for positive manual control of the power enrichment range.

4-5. The preceding instructions did not apply to carburetors equipped with an airflow power enrichment valve, such as PS-5BD, or PS-7BD. The "BD" series enrichment valve is actuated by the airflow through

Carburetor Model	Parts List	Enrichment Valve Screw Setting	Gage Part No.
PS-5C	380179	35° from WO	T25939
	380208	35° from WO	T25939
	380212	35° from WO	T25939
	380223	35° from WO	T25939
	380229	35° from WO	T25939
	380230	35° from WO	T25939
	391318	28° from WO	T25941
	391330	26-1/2° from WO	T25942
	391583	28° from WO	T25941
391629	28° from WO	T25941	
PS-5CD	391527	32° from WO	T25940
PSD-5C	391435	39° from WO	T25938
	391529	31° from WO	T25952
	391572	31° from WO	T25952
PSH-5C	391603	37° from WO	T25997
	391668	31° from WO	T25952
<p>Note: The enrichment valve setting gages are available separately under the above part number, or as a complete set under part number T25937 from your local Bendix distributor.</p>			

Figure 10.

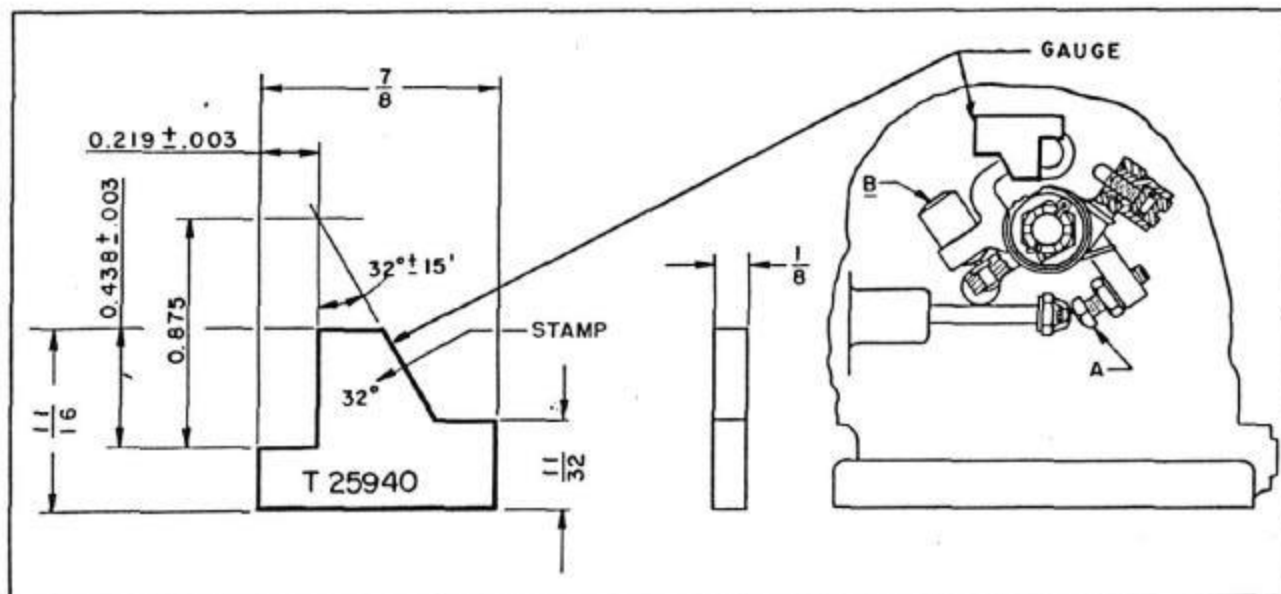

Figure 11. Correct position of adjusting gage when setting the enrichment valve

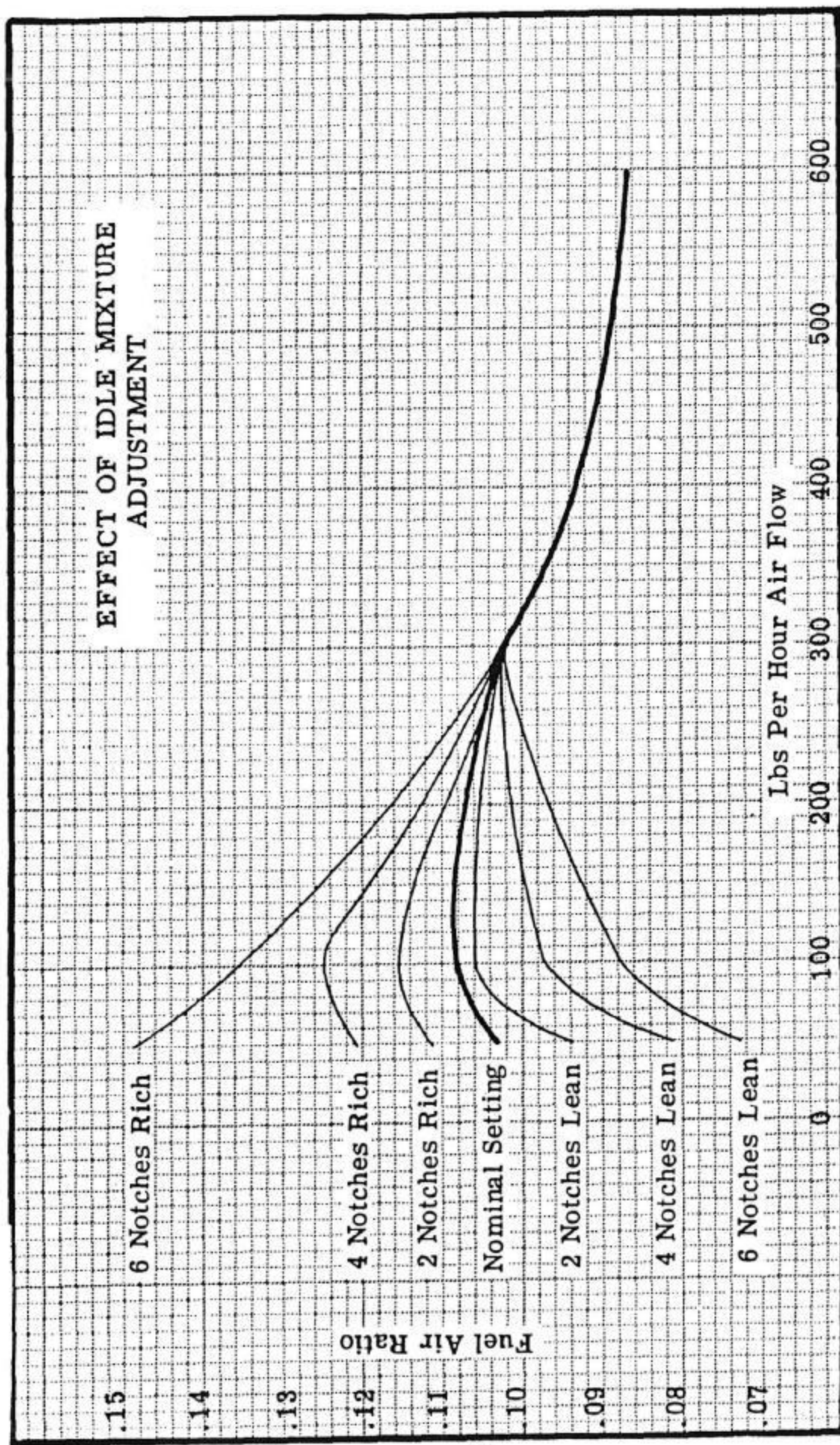

Figure 12.

the carburetor and is adjusted on the flow bench. It is not affected by idle adjustments.

DISCHARGE NOZZLE (Metered Fuel Pressure) ADJUSTMENT

4-6. The discharge nozzle adjustment is made on the flow bench during testing and calibration of the carburetor. However, in an early Bendix publication, form 10-849 dated 1-7-49 titled Handbook of Instructions with parts catalog for Stromberg PS series injection carburetors, a procedure was outlined for adjusting the discharge nozzle with the carburetor installed on the aircraft. Since the publication of the above handbook, aircraft engine performance has changed considerably with regard to horsepower and compression ratio. This, in itself, has made field adjustments of the discharge nozzle more critical and dangerous from the standpoint of causing possible damage to the engine.

a. Adjustments made to the discharge nozzle have not been considered approved field adjustments. However, on recent production carburetors, a limiting device has been incorporated which permits safe adjustment of the discharge nozzle in the field (See figure 13). The discharge nozzle adjustment limiter may be installed on any PS carburetor at time of overhaul.

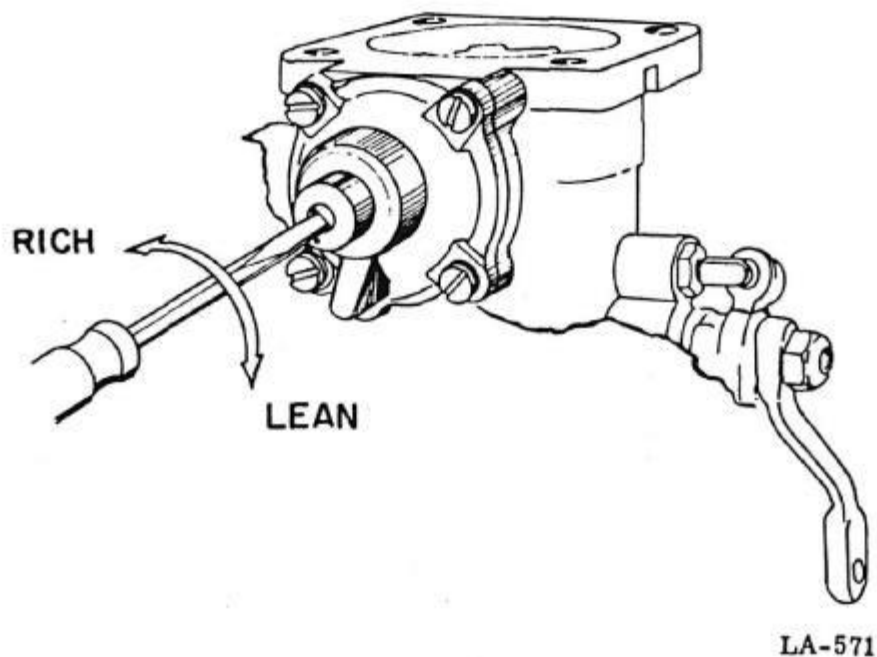

Figure 13.

b. One of the most frequent fuel metering complaints of operators has been engine roughness and RPM fluctuation in the off-idle range (between idle and cruise power). Variations in climatic conditions, particularly where severe changes in ambient air temperatures occur, contribute to this condition. Carburetors incorporating the limiter device may be safely adjusted to shift the off-idle fuel schedule in a rich or lean direction to compensate for variations in engine requirements.

4-7. If engine roughness occurs in the off-idle range and all other probable causes for roughness have been eliminated, the discharge nozzle may be adjusted on carburetors incorporating a discharge nozzle adjustment limiter, as follows:

a. Make normal idle speed and mixture adjustment as described in paragraph 4-1.

b. With engine oil temperature and cylinder head temperature still in normal, make mixture checks in the 1200 to 1500 RPM range and observe for maximum RPM rise.

(1) The mixture check must be made with the propeller control in full low pitch (high RPM) and with the aircraft headed into the wind. Manually lean by pulling the mixture control slowly toward idle cut-off. As the fuel flow is being leaned, observe for the maximum momentary RPM rise which should occur just before the RPM starts to fall off. Immediately return the mixture control to full rich to prevent the engine from dying.

(2) If an RPM rise occurs, the carburetor setting is on the rich side of best power mixture.

(3) If there is no RPM rise, the carburetor setting is at or leaner than best power mixture.

NOTE

The adjusting screw contains a spring-loaded ball, and the sleeve has internal splines to provide a lock for the adjustment and a notch measurement of the amount of adjustment being made.

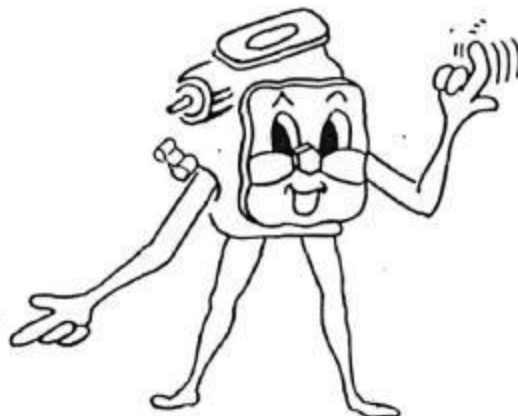

c. If mixture checks indicate a poor mixture setting, adjust the discharge nozzle to get a maximum rise not to exceed 50 RPM in the off-idle range, or until smooth engine operation is restored.

(1) To richen the off-idle range, insert a screwdriver through the end of the discharge nozzle adjustment locking cap and turn the adjusting screw in a counterclockwise direction one notch at a time until the desired engine operation is obtained.

(2) To lean the off-idle range, turn the adjusting screw in a clockwise direction one notch at a time until the desired engine operation is obtained.

(3) Clear the engine before each mixture check by running up to cruise power.

(4) Repeat the mixture check after each nozzle adjustment.

d. Make mixture check at 1700 RPM.

(1) Look for a 5 - 25 RPM rise.

e. After the off-idle mixture has been adjusted with the discharge nozzle adjustment, it will be necessary to readjust the idle.

(1) When resetting the initial idle, use only the normal idle speed and idle mixture adjustments.

(2) The idle should be adjusted to give the lowest possible manifold pressure at the desired engine speed (usually 600 RPM).

(3) A mixture check at the idle point should give approximately a 10 RPM rise.

4-8. The chart (Figure 14) illustrates the effect of a maximum rich and maximum lean adjustment of a discharge nozzle which incorporates a limiter device. The center line represents the normal fuel-air ratio schedule of a carburetor as set on an air box or flow bench. Assuming a lean or rich condition exists causing engine roughness in the off-idle range, the discharge nozzle could be adjusted accordingly. Notice that an adjustment will produce considerable change in the off-idle range, however, the cruise and power ranges are affected only slightly.

NOTE

It will be necessary to readjust the idle mixture after any adjustment of the discharge nozzle. With the PS-5C type carburetor (mechanical enrichment) it is necessary to reset the enrichment valve opening point following an idle mixture adjustment.

4-9. The air flow enrichment valve adjustment is made on the flow bench during testing and calibration of the carburetor. It is sealed at time of carburetor calibration and is not an approved field adjustment.

4-10. The nominal setting of the enrichment valve is to start to open at approximately 50% rated power. The approximate cruise power of aircraft using the "BD" type carburetor is from 60 to 65% of rated power which means that climb and cruise power settings are within the enrichment valve operating range and any adjustment made to the enrichment valve will affect these power settings. However, if rough engine operation occurs in the cruise range or during climb due to an excessive rich mixture, the enrichment valve may be adjusted one click at a time in a clockwise direction to lean or delay the enrichment valve opening point until the desired operation is acquired.

a. If roughness and/or detonation occurs at cruise powers and/or high cylinder head temperatures at rated climb and take-off power settings, the enrichment valve adjustment may be reset to open quicker by turning the adjustment one click at a time in a counter-clockwise direction until the desired enrichment is obtained.

b. It should never be necessary to turn the enrichment valve adjustment more than one-half turn rich or lean to obtain the desired setting.

c. If frequent adjustments to the discharge nozzle pressure or enrichment valve are necessary to maintain operation, the carburetor should be removed and completely overhauled and recalibrated.

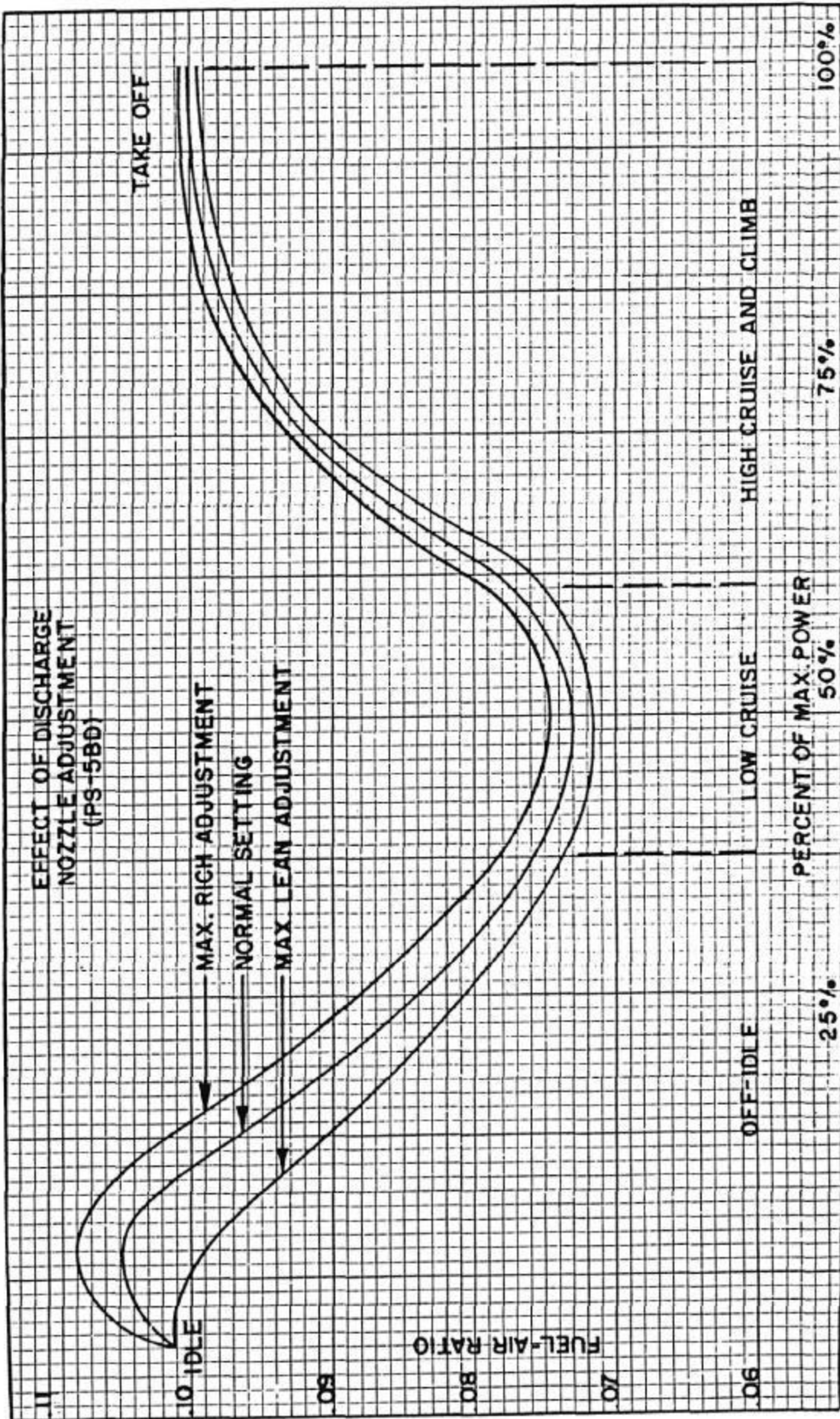

Figure 14.

SECTION V

MAINTENANCE, LUBRICATION & PREPARATION FOR STORAGE

MAINTENANCE

5-1. In general, little attention is required between carburetor overhauls. However, it is recommended that the following items be checked during periodic inspections of the engine.

a. Check tightness and lockwiring of all nuts, bolts and studs which fasten the carburetor to the engine and air scoop to the carburetor.

b. Check the fuel line, vapor vent line and pressure gage connection for fuel leakage.

c. Check throttle and mixture control rods and levers for tightness and lockwiring.

d. Remove and clean the carburetor fuel inlet strainer at the first 25 hour inspection and each 50 hour inspection thereafter. Use a new 365533 strainer plug gasket each time the strainer is reinstalled.

5-2. Current production of some models of the "PS" series carburetors will incorporate a 200 mesh fuel inlet strainer and an 80 mesh fuel strainer around the poppet valve assembly. These carburetors will be identified with the letter "S" stamped on the face of the hex head poppet valve cover. If on inspection of the 200 mesh fuel strainer it is found to have more than 50% of the screen area plugged with dirt and lint, the poppet valve strainer should also be removed and cleaned.

CAUTION

Extreme care must be taken in the removal of the poppet valve strainer so as not to drop or lose the poppet valve and/or poppet valve return spring. Also, no attempt should be made to incorporate a poppet valve screen in a carburetor which has not had



the valve seat replaced or reworked during overhaul to include an annulus to receive the open end of the poppet valve strainer assembly.

5-3. The replacement of the 80 mesh fuel inlet strainer with a 200 mesh strainer can only be made when the airplane has been modified to incorporate a 200 mesh fuel strainer in the fuel system somewhere between the fuel tank and the carburetor. The finer mesh strainers are being incorporated to minimize the possibility of carburetor malfunction due to the induction of dirt, metal particles, lint and/or other contamination from the fuel and/or the fuel system such as lines, tanks and related fuel connections. The "PS" series carburetors will digest a considerable amount of dust and small particles of dirt. However, service experience has shown that metal particles, thread cuttings from fuel system fittings and small quantities of gas-tite or thread lube are getting into the carburetor poppet valve cavity and causing possible engine stoppage due to an over-rich mixture caused by the poppet valve being held open by this contamination.

a. It is advisable for maintenance personnel to include these additional fuel system screens as soon as possible and to use care in their periodic inspection of the fuel system.

5-4. Tests have proven that gasoline which has become stale due to prolonged storage, absorbs oxygen rapidly. This stale oxidized gasoline acquires a very distinctive odor similar to varnish and causes rapid deterioration to synthetic rubber parts and also forms a gummy deposit on the internal metal parts. This condition, however, does not occur during normal operation of the carburetor where fresh fuel is being constantly circulated.

5-5. If it is known that an airplane is going to be taken out of service, for a period of more than 10 days, it is recommended that the fuel section of the carburetor be completely drained of all fuel. (See Section III, Paragraph 9.) Install drain plugs and connect an oil supply line to the carburetor fuel inlet and inject oil into the carburetor at 5 psi. The oil must be Grade 1010 conforming to Aeronautical Specification No. MIL-O-6081. Continue pumping oil to the carburetor until oil flows from the discharge nozzle insuring that the carburetor is completely filled.

5-6. If practical, the following alternate method can be used for short storage periods. Instead of oil flushing the carburetor, the fuel system may be pressurized every 3 or 4 days on airplanes incorporating a fuel boost pump. This is accomplished by placing the mixture control in "Rich" and moving the throttle to half open position, then momentarily operating the boost pump until fuel starts

to flow from the manifold drain. Return mixture control to cut-off and close throttle valve. This will insure that the carburetor is completely filled with fuel.

LUBRICATION

5-7. There is very little need for lubrication of the carburetor in the field between regular overhauls. However, the clevis pins used in connection with the throttle and manual mixture control levers should be checked for freedom of movement and lubricated, if necessary, as directed in the airplane manufacturer's handbook.

PREPARATION FOR STORAGE

5-8. Any unit taken out of service or units being returned for overhaul must be flushed with preserving oil (Specification MIL-O-6081, Grade 1010), using the following procedure:

a. Remove plugs and drain all fuel from the carburetor, then apply 10 to 15 psi air pressure to the carburetor inlet, until all fuel is discharged from the discharge nozzle.

b. Replace plugs and apply flushing oil filtered through a 10-micron filter at 13-15 psi to the carburetor fuel inlet until oil is discharged from the discharge nozzle.

c. Replace fuel inlet shipping plug.



Do not exceed the above air pressures as internal damage to the carburetor may result.



d. After filling with preservative oil the carburetor should be protected from dust and dirt, and given such protection against moisture as climatic conditions at the point of storage require. In most cases, storing the unit in a dry area will be sufficient.

e. If the unit is to be stored near or shipped over salt water, the following precautions should be observed:

(1) Spray the exterior of the carburetor with an approved preservative oil.

(2) Pack in a sealed dustproof container, wrap the container with moisture and vaporproof material and seal. Pack the wrapped unit in a suitable shipping case.

NOTE

Pack a one-half pound bag of silica gel crystals in the dustproof container with the carburetor. The bag must not touch the carburetor.

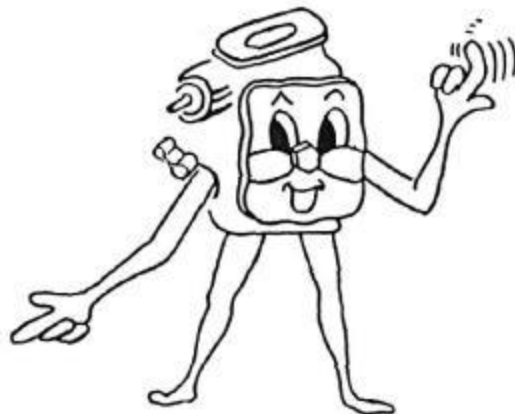

CAUTION

Extreme caution should be exercised when handling or working around the carburetor to prevent oil or fuel from entering the air sections of the carburetor. As explained previously, damage to the air diaphragm will result. Fluid can easily enter the air section of the carburetor through the annular groove around the venturi at the scoop mounting flange. For this reason some protection plate should be installed on the scoop mounting flange when performing routine maintenance on the engine, such as washing down the engine and air scoop, servicing the air filter (surplus oil on the element) or when injecting preservative into the engine prior to storing or shipping.



SECTION VI

CARBURETOR NOTES, GROUND & FLIGHT

6-1. INDUCTION SYSTEM ICING. There are two types of icing conditions which are of considerable concern to the operator of any airplane. The first is ice formation due to fuel vaporization and the second is rime or atmospheric icing. The conditions that bring about these two ice formations are considerably different in their origin and therefore will be discussed separately.

6-2. VAPORIZATION ICING. Ice formation within the carburetor due to fuel vaporization, or refrigeration, is a result of a temperature drop at the point of fuel injection into the air stream. The rapid vaporization of the gasoline at the point of injection can result in a 40°-70°F drop in temperature. As moisture is always present in engine intake air, ice will form in the immediate area downstream from the discharge nozzle, (point of injection). In a float type carburetor, this ice will usually form on the throttle valve and shaft, and if permitted to accumulate, will restrict the induction system to such an extent as to cause complete engine failure.

a. One of the main advantages of the "PS" type of carburetor is its "non-icing" characteristics. As fuel is discharged directly into the intake manifold the possibility of fuel vaporization within the throttle body of the carburetor is eliminated. However, under ideal icing conditions, ice may form in the manifold riser and will be evidenced by a gradual loss of power or erratic engine operation. This condition can be corrected by the application of carburetor heat.

6-3. ATMOSPHERIC ICING. Atmospheric or rime ice will usually form when flying through heavy rain, snow or ice when the temperature is in the vicinity of 32°F. This type of ice not only collects on the wing and propeller surfaces of the aircraft, but may completely restrict the inlet air scoop filter. As this ice cannot be removed by the application of carburetor heat, continued flight must be made on either heated or protected intake air.

6-4. RAIN. When operating an aircraft in areas of heavy precipitation, unstable metering of fuel by the carburetor may be experienced. That is, the carburetor may seem to go "rich" or "lean". This unstable effect is the result of water passing through the air sections of the carburetor and seems to have the greatest effect on downdraft installations.

a. Lean conditions may result from water passing through the venturi tube, thus causing a reduction in venturi suction, and on carburetors equipped with an automatic mixture control when water passes through the AMC needle orifice.

b. Unstable metering on PSD carburetors may result from water passing through the vacuum reducer and will usually be apparent by rough engine operation.

c. Standpipe type vacuum reducers are now incorporated in PS downdraft models to minimize the effect of the natural moisture traps in the air sections resulting from its installed attitude.

6-5. ICE AND SNOW. Power loss resulting from induction system restriction is often encountered when operating under these conditions. The restriction can form in the air scoop, air filter, or carburetor screen, (if used). Preventative action consists of merely the moderate application of carburetor heat prior to entering this type of precipitation. In the event a restriction has already accumulated, the application of carburetor heat and/or protected air source must be sufficient enough to raise the temperature of the critical areas above freezing.



The maximum C.A.T. specified by the engine manufacturer must not be exceeded.



6-6. To summarize the foregoing paragraphs, it has not been practical to provide features that would completely eliminate operational difficulties due to icing. An even distribution of heated air available for the induction system will allow operation of the aircraft under adverse weather conditions by pilots instructed in precautionary and corrective measures.

FLIGHT NOTES ON THE AUTOMATIC MIXTURE CONTROL AND AIRFLOW ENRICHMENT VALVE

6-7. In an aircraft engine without super-charger, a loss of power is experienced with any increase in altitude above sea level, due to

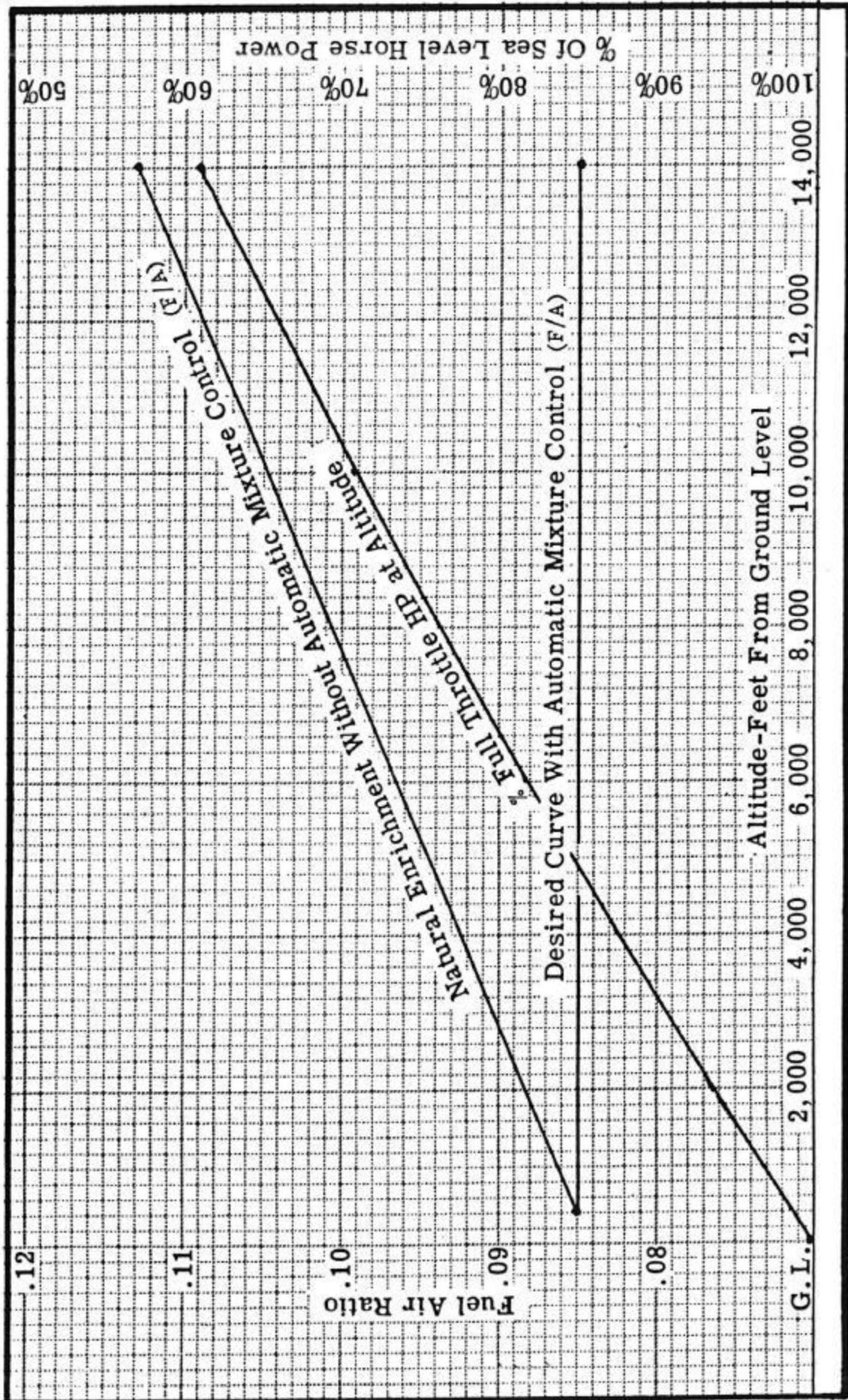
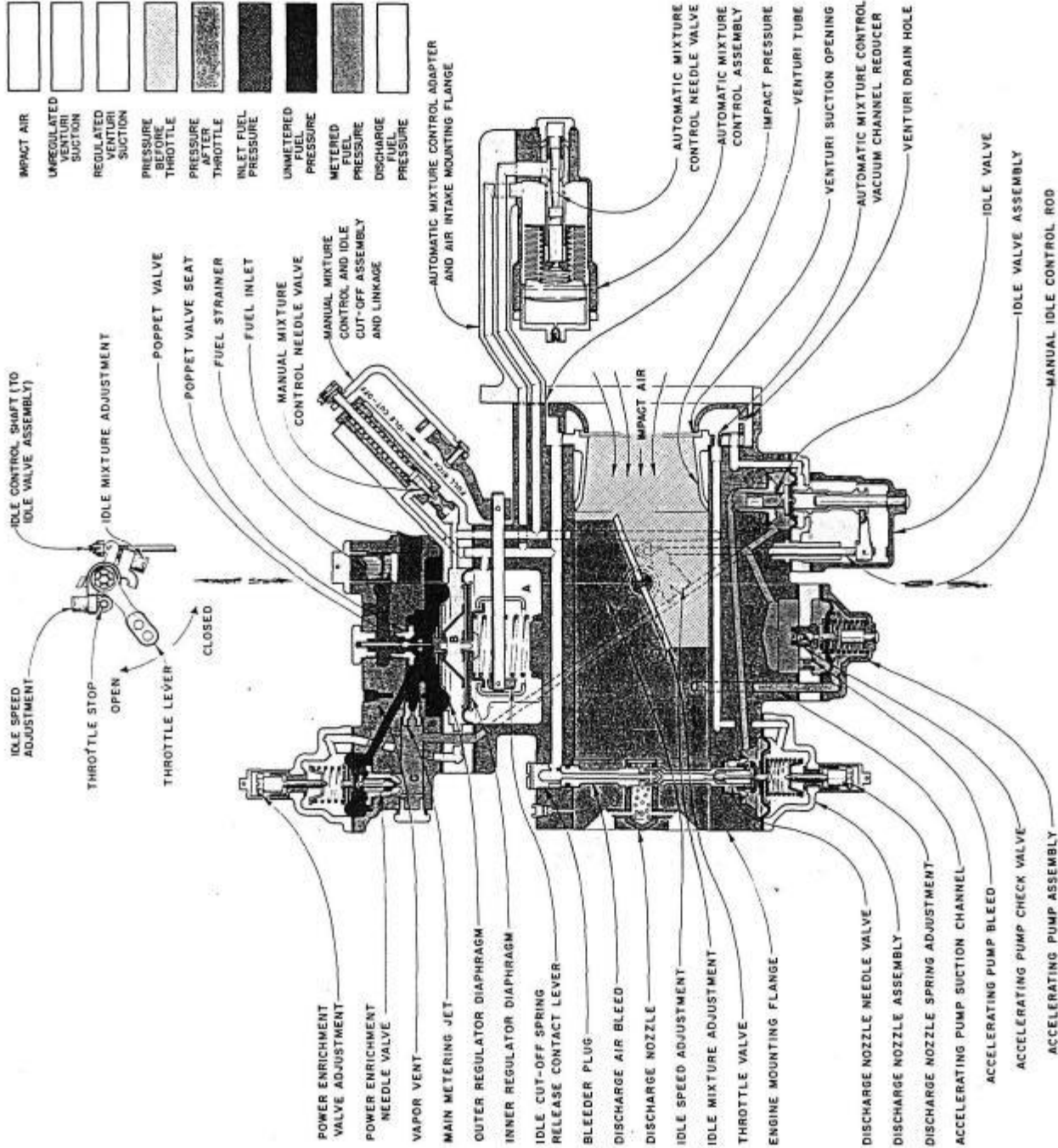

Figure 15.

the lower air density or lighter atmosphere (pounds per cubic feet). As an example an engine without super-charger at 1000 feet will develop approximately 96.8% of its rated sea level full throttle horsepower, at 10,000 feet 70.8% and at 20,000 feet only 48.0%. (Refer to chart, figure 25.)

a. The automatic mixture control, through its air pressure and temperature sensing bellows arrangement, controls the position of a contoured needle in an orifice. Each position of the needle in relation to the orifice represents a different air density condition with correction for prevailing carburetor air inlet temperature. The automatic mixture control through this mechanical arrangement automatically regulates the venturi suction force applied to chamber "B" of the regulator, effecting the necessary fuel flow adjustment to meet each change in engine requirement.

6-8. The same controlled venturi suction established by the automatic mixture control is also applied to the air side of the airflow enrichment valve diaphragm, controlling the amount of enrichment valve opening. Thus the regulating action of the AMC also reflects in the amount of enrichment valve opening. This combination gives the desired correction for variations in the engine load requirements through the enrichment range (approximately 50% to 100% of sea level rated horsepower) during both part throttle and full throttle operation. It must be remembered that it is the function of the carburetor with automatic mixture control unit and airflow enrichment valve to maintain a correct fuel-air ratio to the engine regardless of power, load or altitude conditions so that the maximum possible percent of sea level horsepower can be obtained automatically for each service altitude.



Schematic Diagram of the Stromberg PSH-7BD Injection Carburetor

Copyright © 1956, 1958
 THE BENDIX CORPORATION
 South Bend, Indiana 46620

